

United States Department of the Interior
National Park Service

National Register of Historic Places Registration Form

This form is for use in nominating or requesting determinations for individual properties and districts. See instructions in National Register Bulletin, *How to Complete the National Register of Historic Places Registration Form*. If any item does not apply to the property being documented, enter "N/A" for "not applicable." For functions, architectural classification, materials, and areas of significance, enter only categories and subcategories from the instructions.

1. Name of Property

Historic name: Ramona Main Street Colonnade

Other names/site number: _____

Name of related multiple property listing: _____



(Enter "N/A" if property is not part of a multiple property listing N/A)

2. Location

Street & number: State Route 67/78 – Main Street

City or town: Ramona State: CA County: San Diego

Not For Publication: Vicinity:

3. State/Federal Agency Certification

As the designated authority under the National Historic Preservation Act, as amended,

I hereby certify that this ___ nomination ___ request for determination of eligibility meets the documentation standards for registering properties in the National Register of Historic Places and meets the procedural and professional requirements set forth in 36 CFR Part 60.

In my opinion, the property ___ meets ___ does not meet the National Register Criteria. I recommend that this property be considered significant at the following level(s) of significance:

___ national ___ statewide ___ local

Applicable National Register Criteria:

___ A ___ B ___ C ___ D

<p>_____ Signature of certifying official/Title:</p>	<p>_____ Date</p>
<p>_____ State or Federal agency/bureau or Tribal Government</p>	

<p>In my opinion, the property ___ meets ___ does not meet the National Register criteria.</p>	
<p>_____ Signature of commenting official:</p>	<p>_____ Date</p>
<p>_____ Title : State or Federal agency/bureau or Tribal Government</p>	

Ramona Main Street Colonnade
Name of Property

San Diego, CA
County and State

4. National Park Service Certification

I hereby certify that this property is:

- entered in the National Register
- determined eligible for the National Register
- determined not eligible for the National Register
- removed from the National Register
- other (explain:) _____

Signature of the Keeper

Date of Action

5. Classification

Ownership of Property

(Check as many boxes as apply.)

- Private:
- Public – Local
- Public – State
- Public – Federal

Category of Property

(Check only **one** box.)

- Building(s)
- District
- Site
- Structure
- Object

Ramona Main Street Colonnade
Name of Property

San Diego, CA
County and State

Number of Resources within Property

(Do not include previously listed resources in the count)

Contributing	Noncontributing	
_____	_____	buildings
<u>1</u>	_____	sites
_____	_____	structures
_____	_____	objects
<u>1</u>	_____	Total

Number of contributing resources previously listed in the National Register N/A

6. Function or Use

Historic Functions

(Enter categories from instructions.)

LANDSCAPE/Tree Colonnade

Current Functions

(Enter categories from instructions.)

LANDSCAPE/Tree Colonnade

7. Description

Architectural Classification

(Enter categories from instructions.)

No Style

Materials: (enter categories from instructions.)

Principal exterior materials of the property: N/A

Ramona Main Street Colonnade
Name of Property

San Diego, CA
County and State

Narrative Description

(Describe the historic and current physical appearance and condition of the property. Describe contributing and noncontributing resources if applicable. Begin with a **summary paragraph** that briefly describes the general characteristics of the property, such as its location, type, style, method of construction, setting, size, and significant features. Indicate whether the property has historic integrity.)

Summary Paragraph

The Ramona Main Street Colonnade along Main Street in Ramona California, consists of a 1.8-mile corridor of over 300 eucalyptus trees, originally established in 1909 and continuing to be maintained and replanted to the present day, by the community of Ramona. Two hundred twenty-six existing trees, reaching up to 70 feet in height, were planted between 1909 and 1931. At least eighty eucalyptus trees have been planted in the intervening years by the Ramona community...many since 2002 by the Ramona Tree Trust (see www.RamonaTreeTrust.org). The Colonnade retains integrity, in its regularity and density of trees, to continue to represent the agricultural history of Ramona. The adjacent agriculturally-focused commercial enterprises and vacant properties continue to provide the Colonnade with historic context.

Narrative Description

The Ramona Historic Colonnade occupies an approximately 1.8-mile extent of Main Street, between Wynola Street on the west and 9th Street on the east. The historic trees are generally greater than 70 feet in height and regularly spaced, forming the appearance of a Colonnade lining Main Street at its entry into the community of Ramona. Over 300 trees of the Colonnade line both sides of Main Street, consisting of 226 historic eucalyptus trees (planted between 1909 and 1931), interspersed with at least 80 smaller trees (planted over the past century by the Ramona community and since 2002 by the Ramona Tree Trust). The historic trees are primarily Red Gums (*Eucalyptus camaldulensis*) and the younger trees are other Eucalyptus species of similar appearance, including many Sugar Gums (*Eucalyptus cladocalyx*) that have been planted in more recent years due to their resistance against borer infestations. The historic trees are located within the California Department of Transportation (Caltrans) right-of-way where they were originally planted by the citizens of Ramona during several episodes in 1909, 1910, 1915, 1920, 1931, and the 1980s and 2000s.

Despite grandiose newspaper reports of the thousands of eucalyptus trees planted in the early twentieth century, the 1928 aerial photographs (see Continuation Sheets, Additional Documentation, page 3) confirm that the major corridor of trees extended historically from Wynola Street to 9th Street and consisted of approximately 626 trees. Although a number of trees have been lost to drought, disease, and development, the community has continued to ensure that replacements are replanted, both by developing property owners and by the Ramona Tree Trust. The result is that, in 2014, the Colonnade is comprised of a total of over 300 eucalyptus trees, roughly half of the original 626, and coincides with the extent from Wynola Street to 9th Street shown in the historic (1928, 1949, 1953, 1960/2) aerial photographs. (This description data is based on a detailed field update and intensive inspection of historic aerial photographic data,

Ramona Main Street Colonnade

San Diego, CA

Name of Property

County and State

completed by Ramona Tree Trust volunteer Carolyn Dorroh in February 2009. The maps updated with February 2009 field data are included as Continuation Sheets, Additional Documentation, pages 4-11.)

As was the situation for most of the Colonnade's history, the adjacent lands on the northwest and southeast sides of Main Street remain a mixture of rural land and commercial properties.

Agricultural enterprises such as feed and hardware stores, equipment rental yards, vehicle repair shops, used vehicle lots, a butcher shop, and a nursery serve Ramona's agricultural needs. These are interspersed with vacant lots, convenience stores, and small sole proprietorships.

Because of the Colonnade preservation and continued rural focus of the community of Ramona, The Ramona Main Street Colonnade retains its historical integrity to still convey the sense of pride and welcome to the community of Ramona.

Integrity of Location: While the historical records suggest the grandiose plans of the Ramona community to plant 50,000 trees along a 6-mile stretch of the highway, review of the historical maps and aerial photographs indicate that, nearly from the time of its planting, the Colonnade existed as an entity along Main Street from approximately Wynola Street to 9th Street. The Caltrans Tree Inventory and the field review conducted for this nomination illustrates that 226 eucalyptus trees of greater than two-foot diameter still comprise the Colonnade between Wynola Street and 9th Street. The Colonnade, as it currently exists from Wynola Street to 9th Street, thus retains integrity of location.

Integrity of Design: The Caltrans tree inventory and the field review conducted for this nomination identify 226 trees greater than two feet diameter that are clearly members of the original planting. Originally planted at regular intervals with the intention of shading Main Street into and through Ramona, the current spacing, height, and numbers of trees that comprise the Colonnade demonstrate that the Colonnade retains integrity of its original design.

Integrity of Setting: Originally conceived to beautify and shade the entrance and center of Ramona, the Colonnade lined Main Street as it traveled through the western agricultural lands and into the eastern commercial town center. Today, the western portion of the Colonnade, from Wynola Street to Letton Street, travels through lands that, while not agricultural, still reflect an open rural setting (see Continuation Sheet, Additional Documentation, Page 15, Photographs 10-11). The Colonnade-lined Main Street then travels into the commercial area of Ramona. Thus, the Colonnade still retains the original rural agricultural as well as small-town commercial setting.

Integrity of Materials: The Colonnade is currently made up of 226 eucalyptus trees that are the original trees planted 100 years ago. Interspersed with the original trees, and in keeping with the method of original planting that spanned several decades, are newer eucalyptus trees of a similarly-appearing species that were selected for their resistance to the Lerp Psyllid infestation and similarity in appearance to the original Colonnade trees. Thus, the Colonnade between Wynola Street and 9th Street retains integrity of materials.

Integrity of Workmanship: The Colonnade retains the spacing and orientation to provide shade and a welcoming feeling that was the intention of the original planters. Its reflection of the care taken with the planting and maintenance is substantiated by the existence of a good portion of the Colonnade trees after 100 years. Maintenance and restoration of the Colonnade is being

Ramona Main Street Colonnade
Name of Property

San Diego, CA
County and State

undertaken by a local charity, the Ramona Tree Trust, which has planted 80 trees along Main Street between 2002 and 2014 under the auspices of and supervised by Caltrans. The Trust intends to plant 100 trees in the Colonnade and is currently planning another phased planting of trees.

Integrity of Feeling: The height and linear alignment of the trees along Main Street lend an imposing ambiance to the entry into the town of Ramona. It is this feeling that is most often referred to by the citizens when speaking or writing about the importance of the Colonnade to the community and its character. Described as “Ramona’s western approach,” “living memorials to our pioneers,” “living history of Ramona,” and “our signature eucalyptus trees,” the Colonnade is repeatedly included in the town’s promotional and historical literature as an emblem of Ramona. The Colonnade has been the focus of the volunteer Ramona Tree Trust both in planting and caring for new trees in the Colonnade as well as efforts to preserve this living legacy bequeathed to the community by Ramona’s pioneers. This community-based activity is further evidence of vital and ongoing community interest and support of the Main Street heritage trees 100 years after they were planted in the historic Colonnade. The Colonnade remains as the signature marker of the town of Ramona and central to its collective heart. The passion of the Ramona community for the Colonnade demonstrates that the Colonnade retains a significant sense of feeling for the community.

Integrity of Association: Although the number of trees in the Colonnade has been reduced through the later decades of the twentieth century, the Colonnade still retains sufficient numbers and density to convey its association with Ramona’s agricultural history and the community’s pride in their town. The Colonnade is unique in the San Diego backcountry region and is remembered by travelers as the gateway to the agricultural backcountry. The Colonnade continues to convey a sense of welcome to Ramona and provide a sense of community pride.

Ramona Main Street Colonnade
Name of Property

San Diego, CA
County and State

8. Statement of Significance

Applicable National Register Criteria

(Mark "x" in one or more boxes for the criteria qualifying the property for National Register listing.)

- A. Property is associated with events that have made a significant contribution to the broad patterns of our history.
- B. Property is associated with the lives of persons significant in our past.
- C. Property embodies the distinctive characteristics of a type, period, or method of construction or represents the work of a master, or possesses high artistic values, or represents a significant and distinguishable entity whose components lack individual distinction.
- D. Property has yielded, or is likely to yield, information important in prehistory or history.

Criteria Considerations

(Mark "x" in all the boxes that apply.)

- A. Owned by a religious institution or used for religious purposes
- B. Removed from its original location
- C. A birthplace or grave
- D. A cemetery
- E. A reconstructed building, object, or structure
- F. A commemorative property
- G. Less than 50 years old or achieving significance within the past 50 years

Ramona Main Street Colonnade
Name of Property

San Diego, CA
County and State

Areas of Significance

(Enter categories from instructions.)

Community Planning and Development

Period of Significance

1909-1970

Significant Dates

Significant Person

(Complete only if Criterion B is marked above.)

Cultural Affiliation

N/A

Architect/Builder

Statement of Significance Summary Paragraph (Provide a summary paragraph that includes level of significance, applicable criteria, justification for the period of significance, and any applicable criteria considerations.)

Summary

Ramona's Main Street Eucalyptus Colonnade (see Maps 1 and 2 for location) is eligible at the local level of significance for listing in the National Register of Historic Places under Criterion A. in the area of Community Planning and Development. The period of significance is 1909-1970, the period from the colonnade's first planting until a 1970 campaign by students to save the trees from encroaching development.. Because the resource is older than 50 years and the period of significance overlaps the 50-year threshold by only a few years, the property does not need to satisfy the requirements of Criteria Consideration G.

Ramona Main Street Colonnade
Name of Property

San Diego, CA
County and State

Narrative Statement of Significance (Provide at least **one** paragraph for each area of significance.)

Statement of Significance: Criterion A, Urban Planning and Development

For over 100 years, the Eucalyptus Tree Colonnade has characterized the Main Street of Ramona as well as welcomed travelers into San Diego’s rural agricultural backcountry. Originally planted by the town’s boosters in 1909 and enhanced over the decades of the 20th and 21st centuries, the Colonnade is a physical symbol of the townspeople’s pride in their agricultural community. The Colonnade is integral to the historic town landscape, tying together the surrounding agricultural lands with such historic Main Street structures as the Town Hall, the Verlaque House, and multiple blocks of “false front” commercial buildings. Today as well, the Colonnade is a vital link to Ramona’s agricultural history and is a well-known visual feature to urban travelers, often characterized as the gateway to the backcountry. As such, it has made and continues to make a significant contribution to local history and cultural heritage and is eligible under Criterion A.

The community of Ramona cooperated to plant the first Colonnade trees in 1909 with additional plantings documented in subsequent decades of the early 20th century. The 1970 campaign by high school students and vocal support of Ramona pioneer family members were successful in including preservation of the trees in State Route 67/Main Street improvement planning. Despite continued development threats to the Colonnade, continued preservation efforts have prevailed and the Colonnade retains the character that defines its significance under Criterion A.

Historic Context

Agricultural Community History: San Diego Region and Ramona

Although in the twenty-first century, urbanization has expanded throughout San Diego County, rural agricultural (both ranching and farming) has defined the character of the backcountry for 250 years. Agriculture began almost as soon as the Spanish colonists arrived in San Diego Bay in 1769. Settlement during the Spanish period focused on the Presidio defensive post at the opening of the San Diego River into San Diego Bay and on the Mission San Diego de Alcala several miles inland on the north terrace of the San Diego River valley. The mission rapidly incorporated huge tracts of surrounding valleys and mesas into cattle and horse pasturage. The inland valleys became a part of this pasturage and were the richest grazing lands of the mission. The mission’s influence was only limited in the southern San Diego County back country; however, successful ranches and *assistencias* were established in the mountains at Pala, El Valle de San Jose (Warner’s Ranch), and Santa Ysabel. Development of the Santa Ysabel Mission in 1818 established communication and a traveled route from San Diego to the mountains, through

Ramona Main Street Colonnade
Name of Property

San Diego, CA
County and State

the Santa Maria (Ramona) Valley. This traveled route to the backcountry was the origin of today's State Route 67 and Ramona's Main Street.

After the Mexican revolution and subsequent secularization of the mission, Jose Joaquin Ortega and son-in-law, English Captain Edward Stokes were granted, in 1843, the Rancho Santa Maria o Valle de Pamo—17,708 acres including today's community of Ramona. During this time, the road through Ramona valley was a part of the established travel corridor to San Diego, with routes departing from the valley to the northwest through San Pasqual or to the southwest through today's Lakeside. To the east the route traveled to Warner Ranch, Julian, over the mountains to the Colorado Desert, and eventually to the Colorado River, Yuma Arizona, and Sonora, Mexico. Stokes' home was along this route at the east end of the valley. In 1848, Captain Gillespie and his volunteers camped at the Stokes Rancho home before joining the ill-fated Kearney expedition in the Battle of San Pasqual (Pourade 1963). Shortly thereafter, in the 1850s, the route was the last leg of the San Antonio-San Diego Overland Mail Route, the first Continental Mail Route that arrived in San Diego to great celebration in 1857, as well as the Butterfield Stage route.

The valley continued as Ortega's and Stokes' grazing land after the American takeover of California in 1848. In 1872, and after receiving American patent to the land, Captain Stokes' son, Adolfo, sold all but 1000 acres to Juan B. Arrambide. In partnership with Arrambide, French immigrant Bernardo Etcheverry developed the valley in fruit orchards, grain fields, and grazing lands (LeMenager 1989). By the late 1870s, Etcheverry had 12,000 head of sheep grazing in the valley. However, the steady flow of Yankee settlers into California began to reach the Santa Maria Valley by the 1880s.

During the late 1880s, San Diego and all of southern California experienced an economic boom unparalleled in the history of the region up to that time. Land speculation provided the real stimulus to the economic boom. Land speculation fever seized San Diego in the spring of 1887. Speculators formed land companies and subdivided town sites throughout the county, including Escondido, Ocean Beach, El Cajon, Lakeside, and Ramona (Pourade 1964:167-191). In the 1880s, Milton Santee, an engineer and land speculator, was part of an investment group that bought 6000 acres of the Santa Maria rancho, subdividing it into smaller tracts for ranches and farms (Pourade 1964). Main Street was established as the focus of Santee's Subdivision Map 644 in 1890 (San Diego County Recorder's Records 1890).

The real estate boom also stimulated a dramatic demand for county agricultural lands as farmers moved into the county's coastal and foothill valleys that constituted the choice agricultural

Ramona Main Street Colonnade
Name of Property

San Diego, CA
County and State

regions of the growing city's vast hinterland (Van Wormer 1986a). Southern California's weather had manifested an abnormally wet cycle during the late 1870s through the 1880s, fostering the belief that most crops could be successfully grown without irrigation. It was stated that with repeated plowing following the rains to work moisture into the soil combined with thorough cultivation to keep fields free of weeds, dry farming could be depended upon. This promotion led to the rapid occupation of San Diego County's backcountry foothills during the 1880s. The number of San Diego County farms increased from 696 in 1880 to 2,474 by 1890 (United States Census 1883:34-35; 1890:124-125). Most settlers took up unoccupied government land through homesteads, timber claims, or purchase (Van Wormer 1986a; 1986b). This backcountry boom brought increased settlement of the Ramona area by pioneer farmers.

Agriculture, either crop cultivation or livestock raising, continued to be the primary land use in the Santa Maria Valley throughout the remainder of the nineteenth century and in to the early twentieth century. By the turn of the century, a network of dirt roads defined the community of Ramona—a checkerboard in the outlying areas reflecting the subdivision into farm plots. Ramona had developed into a farming community of individuals tied together through geographical boundaries, a common schoolhouse, and a church. The community's pride centered on Main Street where important commercial businesses, such as the Verlaque General Store, the famed Kenilworth Inn, and the Town Hall built by Augustus Barnett, were soon established (LeMenager 1989:88-97).

Eucalyptus Tree History: Southern California and Ramona

By the first decade of the twentieth century, the rural agricultural landscape of the Ramona Valley began to be characterized by windrows and groves of eucalyptus trees. Easily grown, eucalyptus were planted in Ramona to provide windbreaks and shade, to indicate property boundaries, to augment fence lines, to validate land claims on public lands, and to serve as renewable sources of wood for firewood and miscellaneous other uses.

Eucalyptus trees were introduced into California from Australia in the mid-1800s. Various reasons are suggested for their desirability at that time including the ease of shipping the seeds and the need for quick-growing sources of wood for fire, construction, and landscaping. Varieties of the Eucalyptus tree were initially introduced and sold in San Francisco and East Bay nurseries as garden ornamentals. Early San Francisco propagators of the eucalyptus included W.C. Walker, owner of the Golden Gate Nursery in San Francisco, and Dr. H.H. Behr, a botanist who imported and cultivated eucalyptus in the 1850s (Santos 1997a:8).

Ramona Main Street Colonnade
Name of Property

San Diego, CA
County and State

As the nineteenth century progressed, both Federal and State government programs encouraged tree protection and planting throughout California. State laws in 1862 and 1868 disallowed cutting of trees and encouraged tree planting along California roads. Many eucalyptus tree groves were planted as timber claims, encouraged by the 1873 Federal law that gave 160 acres to individuals who planted 40 acres in trees and maintained them for eight years (Santos 1997a). Soon, Eucalyptus plantings began to appear near homes, along country roads and next to barns throughout northern California, where they provided shade and landscape decoration. As an easily-replenished resource due to its rapid growth and large size, the Eucalyptus, by the 1860s, was quickly perceived as an answer to the increasing demand for both fuel and timber by California's quickly expanding population (Barratt 2007).

The eucalyptus arrived in southern California by the 1870s. Albert Workman planted eucalyptus from seed obtained from his native Australia, on his Canoga Park ranch in the early 1870s. Ellwood Cooper and J. L. Barker of Santa Barbara County planted 100 acres with 150,000 blue and red gum eucalyptus in 1872. Widney and Nadeau groves were planted near Los Angeles in 1874 and 1875 (Santos 1997a:10). Ellwood Cooper, in a lecture at Santa Barbara College, promoted the planting of tree belts to beneficially affect climate and beautify landscapes. His argument for the widespread planting of the quick-growing and easily propagated eucalyptus tree was instrumental in the widespread planting of the trees in southern California in the late nineteenth century (Santos 1997a:11).

As the promotion of railroad access to the West Coast grew during the 1870s and 80s, The Central Pacific became actively interested in planting eucalyptus for railroad construction. In the 1870s, the railroad reportedly planted a million trees in the San Joaquin Valley (Santos 1997b:12). Between 1877 and 1885, the Southern Pacific Railroad planted 44,000 eucalyptus trees to be used as telegraph poles and rail ties. Between 1906 and 1910, 8800 acres of Rancho Santa Fe had been planted in three million eucalyptus trees. It is reported that the railroad mania stimulated similar plantings of trees in other parts of the County (*San Diego Union*, 12/6/1959, quoted in Stanford 1970:6).

In the first decade of the twentieth century, a flurry of promotional publications created a boom of eucalyptus planting, primarily with the hopes of reaping profits from the sale of the wood for construction. From Fall 1909 to Spring 1910, 23,000 acres in California were planted in eucalyptus, mostly red and blue gums (Santos 1997a:17). From the 1880s through the twentieth century, the Federal Government, California Forestry Bureau, the University of California Berkeley College of Agriculture, and many local municipalities, promoted the eucalyptus for

Ramona Main Street Colonnade
Name of Property

San Diego, CA
County and State

shade, to beautify parks and streets, to enhance ranch and residential landscapes (Santos 1997a:12). By the twentieth century, eucalyptus trees were common on the California landscape, used for fuel, windbreaks, medicines, shade, and beautification (Santos 1997a:13).

Unfortunately, as the railroads had discovered in the late nineteenth century and the construction industry discovered in the early twentieth, the eucalyptus wood could not be properly seasoned to create a reliable construction wood. Eucalyptus wood warped, cracked, twisted and became too tough once cured. The boom fizzled and throughout the remainder of the twentieth century, eucalyptus would be used mostly for fuel, windbreaks, and in a few medicines (Santos 1997a:17).

From the late nineteenth century through the early twentieth century, many communities beautified and shaded their roads and highways by planting eucalyptus trees. These efforts were encouraged by State legislation, the first in 1913 and later in 1931, encouraging tree-planting efforts. Examples of state highways planted in eucalyptus during this era include Route 160 near Rio Vista, Route 91 from Fresno to Bakersfield, Highway 99 from Marysville to Modesto, and Highway 17 in the Bay area (Santos 1997a: 23). *Sunset Magazine* identified three sections of Highways 101 and 99 where eucalyptus trees lined a day's drive of roadway (Farmer 2007:21). Two eucalyptus tree roadside and windbreak plantings have been listed on the National Register of Historic Places (Boronda Road in Carmel and the Etiwanda Windbreaks of San Bernardino). As Jared Farmer, Mellon Postdoctoral Fellow with the Huntington-USC Institute on California and the West, observed in a published excerpt from his forthcoming book, "Throughout the state, the stands of gums that lined the entrances to towns became landmarks of home (Farmer 2007: 21).

Because the tree is non-native and because it often stands in the way of development, there have been many removed in the late twentieth century. Faced with planned removals of eucalyptus trees from public lands, developing properties, and public streets, local communities have demonstrated the community importance of these historical trees. In many cases, community efforts have resulted in the preservation of the trees (Santos 1997c:6-7, Farmer 2007:21-22).

Many of the eucalyptus windrows, groves, and roadside tree rows in Ramona were planted during the late-nineteenth/early-twentieth century era. It is said that that the large Munger grove at the intersection of Warnock and San Vicente Roads was planted in anticipation of the construction of the railroad from Foster's station to Ramona (Kunkel n.d.). Eucalyptus timber claims were a common landscape feature of agricultural homesteads in Ramona. Eucalyptus groves were particularly useful in Ramona as windbreaks and many eucalyptus fence line

Ramona Main Street Colonnade
Name of Property

San Diego, CA
County and State

windrows divide hay fields in areas such as along Trayner Road northeast of Mount Woodson and in the Ramona Valley proper (1928 aerial photographs). Because of their quick stump growth after cutting, a eucalyptus grove, such as that at Barnett Ranch, was a handy source of firewood (Philip Parker 1998). However, the eucalyptus trees that line Main Street from the western end of the valley through the eastern end of town were unique in that they were a community undertaking to beautify the town. The eucalyptus Colonnade has been a well-known Ramona feature throughout the twentieth century (LeMenager 1989, Beck 2004).

As Ramona continued to grow and take shape in the first decade of the twentieth century, a major concern of the town's citizens was improving the hot and dusty carriage roads leading in and out of town. As Mrs. Ida Bargar, at the age of 96, recalled during an interview in 1974, "Picture Ramona without Main Street, any eucalyptus trees as an entryway into our town, no vegetation of any kind except brush, and you will see the valley that welcomed a Missouri family which was to become an important part of the Nuevo Ramona history, when the (Bargar) family arrived here in 1891" (Kelly 1974a). Ramonans soon began to plant trees throughout the valley, and particularly on Main Street. Ramonans celebrated Arbor Day in 1904 by "improving the rows of trees on either side of the streets. The tree sites were plowed and harrowed and many trees and flowers were planted, and missing ones replaced" (The *San Diego Union*, 3/23/1904). Laurie Welch, Caltrans researcher of the Colonnade, considered several sources describing differing details on the planting of the eucalyptus trees along the highway. She concluded that the oldest eucalyptus trees comprising the Colonnade today probably date to 1908, when the Ramona Improvement Club, led by A. Foster, and W. E. Woodward, secured an agreement with County supervisors that if the club acquired and planted the trees, then the county would fund their care and protection until they could thrive on their own. Foster said the club planned to plant trees "throughout the Santa Maria Valley." Foster explained that, "One of the routes to be followed will be on the main highway from Ramona to the head of the Foster grade. Another route will be from Ramona to the head of Clevenger Canyon. Both highways are about six miles in length and as the trees are to be set out twenty feet apart nearly 50,000 trees will be used" (San Diego Union 9/9/1908:3). In March or April 1909, the Ramona citizens reportedly succeeded in planting approximately 2,000 sugar gum trees "arranged in a double row, bordering the stage road from the Earl School to the premises of James Booth. With the exception of a half mile tract of adobe located to the east of Etcheverry's and impractical for planting at present, we now have a six mile boulevard in embryo" (*Cuyamaca News* 4/28/1909). What is described is a corridor from approximately 3 miles down Mussey Grade from today's Highway 67 to Eighth Street in Ramona (Ham, Fagot and Ellwel 1992:5).

Ramona Main Street Colonnade
Name of Property

San Diego, CA
County and State

The Cuyamaca News article noted that Colonel D. C. Collier donated all the trees and that the Ramona Improvement Club took charge of the planting. In September of 1909, the *San Diego Union* commended Ramona residents for successfully planting trees for three miles along either side of the main highway toward the top of the Mussey Grade. "Eucalyptus was the tree decided upon for the hardy Australian tree has demonstrated beyond any question of doubt that it can do as well and even better in Southern California than in its native country" (*San Diego Union* 9/14/1909). Because the *Union* reported only three miles of trees planted, half what the Cuyamaca News had reported, Welch argues that half of the trees died soon after planting, as the *Union* reports that "conditions of planting were not too favorable but over 60 percent of the trees made good progress" (*San Diego Union* 9/14/1909). The *Union* added that, "the vacant spots on the roadside will be replanted during the present year or next spring, and in addition, trees will be planted along the road to the top of the grade, about a mile in distance." Regarding the length of the Colonnade of trees that survived the 1909 planting, it is likely that given the harsh soil, the extensive labor needed to provide water and care that the County had committed to, and typically dry Ramona summer conditions and unpredictable frosts, there were many young trees that did not survive (Ham, Fagot and Ellwel 1992). An additional planting in 1910 is recalled by Mrs. Carlin Dougherty when, as a little girl of eight, she and several other young children pulled little wagons filled with small eucalyptus and helped plant over 500 trees on Ramona's main thoroughfare (LeMenager 1989:134). Amy Strong apparently obtained eucalyptus trees from Kate Sessions, noted early botanist in San Diego, and arranged for their planting on Main Street in 1915 (Bernhard 1993:40). Although volunteers reportedly continued to plant and hand-water more trees, the hot Ramona summers hindered the survival of many of the trees (LeMenager 1989:135). Many survived, however, as evidenced by contemporary photographs such as a 1915 photograph of the Kenilworth Inn depicting eucalyptus trees along the Inn's Main Street side (Photograph 1). It is clear that the community of Ramona had sown the seeds of a eucalyptus corridor along the entry to the valley and into their downtown, discontinuous perhaps, but reflecting their pride in the Ramona community. It would survive and continue to be augmented for the next 100 years.

Additional efforts to fill out the Colonnade are documented in 1920 and 1931. Ramona citizens undertook another planting in 1920 as evidenced by photos of Main Street from 1923 and 1924 showing young eucalyptus trees still in their supports lining both sides of Main Street. Unfortunately, development of the commercial district in the 1930s apparently resulted in the removals of most of these trees (Welch 2000:9). Another planting of 52 eucalyptus trees along the highway was completed in 1931 about two miles from town in the heart of the Santa Maria

Ramona Main Street Colonnade
Name of Property

San Diego, CA
County and State

Valley. “Five local Legionnaires under the direction of Godfrey Elliott planted 52 eucalyptus trees Sunday along the highway. The object is to afford shade and add to the beauty of the valley” (*Ramona Sentinel* 2/13/1931).

As a result of nearly two decades of tree planting efforts, the Ramona citizenry had succeeded in establishing the signature Colonnade of eucalyptus trees that became the emblem of the entry into the community of Ramona. The 1928 aerial photographs depict a distinct row of eucalyptus trees lining both sides of the highway from approximately Wynola Street to 12th Street, with additional trees clustered on Main Street near the Town Hall and Kenilworth Inn between 6th and 9th Streets and another column lining Montecito Way to the north. The 1928 extent of the Colonnade is illustrated in Map 3, included in the Continuation Sheets, Additional Documentation, page 3. This tree colonnade extended somewhat to the east in the ensuing twenty years as evidenced by 1949 aerial photographs, at which time the Colonnade can be seen to extend from Wynola Street on the west at least to 9th Street on the east. A 1953 aerial photograph depicts essentially the same Colonnade, extending from Wynola Street on the west to 9th Street on the east and this same extent is shown on aerials flown in 1960 and 1962 (aerial photographs 1928, 1949, 1953, and 1960/2).

The density and character of Ramona and the surrounding backcountry remained little changed throughout the first half of the twentieth century and for several decades after World War II. The community character remained focused on agriculture and the eucalyptus Colonnade along the two-lane highway into Ramona grew to symbolize the entry into this agricultural community and the rural backcountry beyond. An interesting line drawing of the Ramona valley and environs was published in the 1947 El Año Ramona High School Commemorative Annual (Photograph 2). The drawing depicts the historic schoolhouses, set in the context of the Ramona environs by identifying only roadways and topographic features. The only other signifier of the Ramona town proper is a series of trees lining both sides of the roadway—the eucalyptus Colonnade (Kelly 1974c). Additional promotional brochures of this decade and the two following consistently provide views of the Ramona Main Street Colonnade on their covers together with town slogans such as “Here is Ramona in the Valley of the Santa Maria (1947), “Ramona, Land of Good Neighbors, Above the Fog...Below the Frost” (1953), “Ramona” (Avitt 1958), “Ramona, The Valley of the Sun” (Chamber of Commerce circa 1960), “Ramona, Heart of the Heaven on Earth Country, Ramona’s Western Approach” (Chamber of Commerce circa 1960). These covers are depicted in Photographs 3-6. When compared with 2009 photographs from the same vantage points (Photographs 10-11), they illustrate that in the mindset of the Ramona community the Colonnade is the emblem of the community and that a significant segment of the

Ramona Main Street Colonnade
Name of Property

San Diego, CA
County and State

Colonnade persisted in the landscape and as a part of the community's identity throughout the first half of the twentieth century.

Until the backcountry population increases that began in the late 1960s and early 1970s, the community remained quiet, rural, and focused on agriculture. Indeed the late 1960s, County General Plan efforts assessed the community of Ramona as farm and agricultural (*Ramona Sentinel* 1967). The eucalyptus Colonnade along the two-lane highway into Ramona continued to symbolize the auto traveler's entry into this agricultural community and the rural backcountry beyond. Efforts to improve the highway through the Ramona valley and into the back country in the 1960s, however, were harbingers of the conflicts between needed improvements to Highway 67/Main Street and preservation of the Colonnade. Desired improvements to Highway 67/Main Street in 1967 were not of a scale to require tree removals (*Sentinel* 1967b and 1967c). However, by 1970, debate intensified regarding preservation of the trees in the face of proposed road improvements. In 1970, a group of high school students started a campaign to preserve the trees from road construction. Many of the town's pioneer family members contributed statements in support of the trees. Mrs. Hazel Ransom wrote, "These are more than just trees. They are identified with us and have been for more than 80 years. They are living memorials to our pioneers" (Brown 1970). The effort convinced the Division of Highways to look for alternatives to removing the trees in Route 67 improvement planning (Brown 1970). Apparently, these efforts were successful as the 1973 improvements apparently proceeded without removals of the Colonnade trees (*Ramona Sentinel* 1973; Pendergraft 1973). As well, in 1978, San Diego County, in the Ramona Community Plan, identified Main Street and street trees as "certain strong features" to be protected to preserve the rural community character (San Diego County 1978/2006).

Period of Significance Justification

These community efforts to preserve the Colonnade that began in 1970, together with the initial planting date (1909), define the Period of Significance for the Colonnade. A Period of Significance of 1909 to 1970 has been selected for the Colonnade, based on the original planting date of 1909 and the beginning of major Ramona community efforts to preserve the Colonnade in 1970. The community of Ramona cooperated to plant the first Colonnade trees in 1909 with additional plantings documented in subsequent decades of the early 20th century. Historic documents and photographs confirm that the Colonnade persisted throughout the remainder of the century. The 1970 campaign by high school students and comments by Ramona pioneer family members were successful in convincing the Division of Highways to look for alternatives

Ramona Main Street Colonnade
Name of Property

San Diego, CA
County and State

to removing trees in State Route 67/Main Street improvement planning. These preservation efforts culminated in formation of the Ramona Tree Trust, which completes additional plantings and advocates for the Colonnade in the 21st century. Despite continued development threats to the Colonnade, continued preservation efforts have prevailed and the Colonnade retains the character that defines its significance under Criterion A.

The 1980s and 90s brought new threats to the Colonnade from commercial development. Soon after the local newspaper published a photograph (Photograph 7) of the Colonnade with a caption stating, "They serve as an historical reminder of the past for Ramonans" (Wells 1986), the Community Planning Group debated the future of 11 trees planned for removal by the proposed K-Mart shopping center. One planner argued that the eucalyptus trees were central to the desire of Ramonans to maintain a "country city" (Robertson 1988). These debates continued into 1990 and generated additional letters to the editor, Community Planning Group debates, and articles lamenting the destruction of the 80-year old trees (Fiddes 1990, Littlefield 1990, Hasley 1990, Selm 1990, Brandes 1990, Williams 1990). In a front-page article in the *Ramona Sentinel*, Larry Littlefield wrote regarding the removal of 13 trees to allow for construction of K-Mart center, "No protestors appeared at the downing of the familiar trees, but some motorists shouted at workmen when they passed. 'Keep the trees!' yelled one." Angus Tobiason, equipment operator and long time Ramonan, commented, "It's sad to see the big trees fall, they've been such a part of the community. ... When I came here in 1939, these trees looked just like this." (Littlefield 1990).

In 1994, a grove of 70 eucalyptus trees cut down near Etcheverry Street by a private property owner, elicited a comment in the *Sentinel* that, "the absence of the trees changes the look of that area as travelers drive into and out of Ramona" (Kasper 1994). While Caltrans highway improvements and San Diego County development permitting allowed the public to comment and to advocate for preservation, this removal was entirely within the right of the private property owner. The Ramona Community Planning Group could only ask that "property owners in the future would consult the tree alliance before cutting down trees" (Kasper 1994). In the face of these continued assaults on the Colonnade, the preservation dialog escalated through the end of the decade and into the new millenium. In 1995, the front page (Photograph 7) and a headline article of the *Ramona Magazine* was devoted to the Colonnade and a discussion of its current state and threats from development, again reiterating that "Ramona' Eucalyptus trees bordering our main road are a landmark to many travelers and residents" (Smith 1995).

Ramona Main Street Colonnade
Name of Property

San Diego, CA
County and State

By 1992, individuals at the California Department of Transportation (Caltrans) saw the need to inventory and evaluate the Main Street eucalyptus trees. The “State Route 67/78 Ramona Tree Report, Preservation of a Scenic Resource” (Ham, Fagot and Elwell 1992) recommended preservation of the Colonnade between Wynola Street and 10th Street where possible, and to restore trees with Sugar gum, a variety resistant to the Psyllid infestation. The report’s “Ramona Tree Survey” (Fagot 1988-2007), has provided a valuable tool for tracking the status of the trees. Although the report notes the historic component of the tree Colonnade, it makes no historical evaluations and focuses on the determining that the tree Colonnade is an important Scenic Resource.

It was this Caltrans’ effort, combined with community commitment to preserving and replanting of the eucalyptus Colonnade that led to the formation of the non-profit Tree Conservancy. The Conservancy’s purpose is to administer an endowment to fund the preservation, stewardship, replacement, and new planting of trees and native vegetation in the San Diego County area (Graham 1993). The Ramona Tree Trust (Trust) became the first account to be established in the Tree Conservancy to replant trees destroyed by development. The Ramona Tree Trust was seeded by the tree mitigation money that ensued from the removals of Colonnade trees as part of the Albertson’s commercial development. The planner of this innovative mitigation partnership, Caltrans Landscape Architect Larry Fagot, described the program in his informational article in Caltrans’s Environmental Newsletter. “This mechanism allows the new trees to be planted off of the project site while assuring that they are always maintained. The community does not have to tax itself for long-term tree maintenance. The funds stay in the community. The program allows groups to get involved in enhancing their community and participation builds a sense of community pride” (Fagot 1993). Caltrans’ commitment to Ramona Tree Trust and their efforts to maintain the Colonnade through replanting has been fruitful. Since its incorporation by Ramona residents in 2000, the Ramona Tree Trust has worked in close cooperation with Caltrans, has applied for and received encroachment permits to plant along a state highway, and has planted 80 trees in the historic Colonnade along Main Street (State Highway 67) in phased plantings started in 2002. The Trust’s plantings in the Colonnade, carried out over the years to the present (2014), also include years of hand watering by volunteers of the newly planted trees until they become fully established. Additionally, the Trust, which is composed entirely of community volunteers and organized as a 501(c)(3) charity, is a community advocate for the health, maintenance and preservation of the entire Colonnade. Caltrans, the County of San Diego, and the Ramona Community Planning Group have committed to work with the Tree Trust to that end (Alvarez 2000, Leins 2001, Glass 2001, Ramona Community Planning Group

Ramona Main Street Colonnade
Name of Property

San Diego, CA
County and State

2001). To that end in the 2000s, a San Diego County-funded Village Design Group (appointed to lay out future planning goals for Ramona) named one of the three town sectors “the Colonnade,” encompassing the original Colonnade trees.

As these replanting and preservation efforts continued, the Environmental Program of Caltrans assigned a graduate student assistant to prepare a Historic Resource Evaluation Report for the Ramona Colonnade, portions of which have been incorporated into this nomination (Welch 2000). Based on research conducted at local and state archives, Welch evaluated the Colonnade’s eligibility for inclusion in the National Register of Historic Places as a designed historic landscape. At the conclusion of a history of the Colonnade she identified three historical associations that the Colonnade could embody: 1) that the trees were part of the civic improvements that denoted Ramona’s unifying as a city, an event important in local history, 2) that the trees could represent the early twentieth century boom in eucalyptus trees, or 3) that the trees express the nationwide beautification and civic reform movement of the late nineteenth-early twentieth century. For the second and third of these associations she convincingly concludes that the Colonnade does not appear to be a good representative and that there are more notable and more representative tree rows throughout the state. For the first, as representative of Ramona’s civic development, she concludes that the tree Colonnade might be a good representative, but that it lacks integrity to convey the association and be considered eligible for the Register. She bases her determination of lack of integrity on her assessment of the seven qualities of integrity, location, design, setting, materials, workmanship, feeling, and association.

“All of these qualities, except for integrity of location, have been fundamentally compromised because most of the original colonnade has been mostly obliterated. The design and workmanship that Ramona’s early civic planners intended in planting a six-mile colonnade of trees is no longer evident. The setting, feeling, and association has been lost through encroachment of modern commercial development along much of Highways 67 and 78.”

Moreover, the small segment of the original colonnade that remains along the approach to Ramona also lacks integrity even if evaluated as a separate entity. Until recently, the area west of downtown was mostly rural open space and appeared much as it did when the trees were planted in 1909. But since the 1980s, this area has been increasingly developed with modern commercial buildings that undermine the feeling, setting, and association of the colonnade. When driving into Ramona through the colonnade one experiences a fleeting sensation of early 20th century San Diego backcountry, but this impression is altogether too brief. And even though this section has remained intact relative to the rest of the original colonnade, it also shows gaps resulting from tree removals that detract from its intended design. Thus this surviving segment also appears

Ramona Main Street Colonnade
Name of Property

San Diego, CA
County and State

to not be eligible for the National Register of Historic Places as a designed historic landscape” (Welch 2000:12-13).

There are two flaws in Welch’s analysis of the integrity of the Colonnade. The first is related to the extent of the Colonnade as originally planted. Although, as described above on page 14 of this document, the grandiose descriptions in the early newspaper accounts suggest that 50,000 trees were to be planted along a 6-mile stretch of the road, it is clear from later accounts and the 1928 aerial photographs that in reality about 626 trees were established along an approximately two mile stretch of the road from Wynola Street west into the town center. As can be seen from later aerial photographs (aerial photographs, 1949, 1953, 1960/2), a boundary for the Colonnade that persisted through the mid-to-late-twentieth century extends from Wynola Street on the west to 9th Street on the east. It is this approximately 2-mile stretch of the Colonnade that reflected the town’s civic pride and is consistently depicted as the Ramona community’s gateway. It is this 2-mile extent that retains the aspects of integrity necessary to convey its association with the Ramona community.

Secondly, the presence of commercial buildings is not inconsistent with the ambiance of the Colonnade. Throughout the twentieth century, the Colonnade existed along a stretch of the highway that transitioned from rural agricultural farm and ranch lands to the commercial town center. Through the twentieth century, the emblematic depictions of the Colonnade include developed as well as rural landscapes. Clearly, the aspects of the Colonnade’s integrity require addressing how the community envisions them. Throughout the mid-to-late-twentieth century, the community envisioned the stretch of Colonnade from Wynola Street to 9th Street, including farmlands and commercial improvements, as a representation of Ramona.

In 2001, a new threat to the Colonnade, in addition to highway and commercial development, arose when 13 dying trees were removed by Caltrans. These trees were victims of a regional infestation by the red gum Lerp Psyllid. The tree losses were lamented by Caltrans field staff, the Ramona Tree Trust president, the Ramona Chamber of Commerce director, and Ramona Community Planning Group chair, who wrote in a letter to the County Supervisor, “These historic trees represent what our forefathers gave us, a way to remember them. It is our desire to pass this on into the future and be remembered by our future generations. We consider this a living history of Ramona” (Clark 2001:2) (see Photograph 8). In response to the need for Caltrans permits to replace the removed trees, Caltrans staff commented, “that shouldn’t be a problem because Caltrans officials have acknowledged that they understand the emotional connection Ramonans have to the Colonnade (Clark 2001:2). Forty trees were subsequently

Ramona Main Street Colonnade
Name of Property

San Diego, CA
County and State

replanted in several phases by the Ramona Tree Trust (Ramona Tree Trust 2002, Ramona Sentinel 2003).

Mitigation measures to replace trees, advocacy and preservation efforts of the Ramona Tree Trust, and community concern for preservation of the Colonnade, however, did not eliminate the battle to protect eucalyptus trees associated with Main Street. Throughout the decade of 2000, the Colonnade continued to be a focus of concern for the Ramona community (Beck 2004). The Ramona Community Planning Group expressed interest in how the Colonnade would be affected by planned SR 67 proposed widening as well as the County General Plan update (Jenkin 2006, Ramona Community Planning Group 2006, Ramona Village Design Committee 2005). Several newspaper Main articles focused on the history of the Colonnade and its future (Pendray 2008, McNulty 2008, Hall 2008). Numerous letters to the editor of the *Ramona Sentinel* and *North County Times*, as well as personal letters to the Ramona Community Planning Group, were penned (*North County Times* 2008, Kelly 2008, Baker 2008, Williams 2008). Several of these letters were from descendents of the Ramona pioneer families whose members helped plant and maintain the Colonnade trees. "I read about the possible destruction of the beautiful eucalyptus trees on highway 78 in Ramona. I urge you to reconsider. My mother, Florence Bargar (born in 1900 in Ramona) proudly recalled going with her father, John Bargar, in a horse and wagon to water the young trees. After one is destroyed, it will be easier to take others. They are an enhancement of your town. Save them!" (Kelly 2008). In its centennial year (2009), the Colonnade was celebrated with a front-page presentation in the *Ramona Sentinel*, "Ramona's magnificent trees are yours to enjoy. Next time you drive into town from 'down the hill,' take a breath and enjoy what you have been given—a living legacy for you and yours, 100 years of green and still going strong." (Conklin 2009).

Evaluation of Eligibility and Integrity, Ramona Main Street Colonnade

The Ramona Main Street Eucalyptus Colonnade is eligible for listing on the National Register of Historic Places for its local significance under Criterion A, its association with events that have made a significant contribution to the broad patterns of our history. The Colonnade has been a physical manifestation of the pride of Ramonans in their agricultural community and has welcomed travelers into San Diego's rural agricultural back country throughout the twentieth century. The town of Ramona exemplifies the type of rural agricultural community that developed in the backcountry of San Diego in the late nineteenth and twentieth centuries. In the late nineteenth century when many of the rural town sites in San Diego were originally laid out, Milton Santee was similarly developing the subdivision of Ramona. As agricultural enterprises

Ramona Main Street Colonnade
Name of Property

San Diego, CA
County and State

spread throughout the Ramona valley, Ramona's Main Street became the commercial and social focus of the growing community. The planting of the Colonnade was undertaken as an expression of community boosterism, beautification, and pride of the valley residents for their developing community. The Colonnade has continued to express that sense of pride and community welcome throughout the twentieth century. It is a unique feature on the backcountry landscape, noted by all travelers through Ramona to the backcountry beyond.

The Ramona Main Street Eucalyptus Tree Colonnade retains the historical integrity to still convey the sense of pride and welcome to the community of Ramona (see Section 7 page s 5-7 for discussion of the seven aspects of Integrity retained by the Colonnade).

Conclusion

In 2009 the Main Street Eucalyptus Tree Colonnade was 100 years old. The approximately 2-mile extent of the Colonnade has survived with sufficient integrity to still elicit strong feelings and expressions of historical association from the Ramona community. Throughout the twentieth century, the Colonnade has served as the emblem of Ramona, whether on a hand-drawn map for a school yearbook or on the cover of the Ramona Chamber of Commerce brochures. The Colonnade continues to represent the agricultural history of Ramona, the pride of its citizenry, and serve as a visual marker to the traveler that the rural San Diego backcountry lies beyond. Listing of the Colonnade on the National Register of Historic Places would be a fitting historic milestone for the recent centennial anniversary of its planting.

Ramona Main Street Colonnade
Name of Property

San Diego, CA
County and State

9. Major Bibliographical References

Bibliography (Cite the books, articles, and other sources used in preparing this form.)

Published Documents

- Avitt, Pearl M. "Ramona," *Union Title-Trust Topics*, Vol. 12, No. 5, Sept/Oct. 1958. San Diego: Union Title Insurance Company, 1958.
- Barratt, Richard H. and Elizabeth R., "National Register of Historic Places Registration Form for Carmel Valley Road-Boronda Road Eucalyptus Tree Row." On File at the California Office of Historic Preservation, 2007.
- Beck, Darrell. *On Memory's Back Trail, A Story History of Ramona and the Backcountry of San Diego*. Carlsbad: Trade Printing Services, 2004.
- Bernhard, Amy Irene. *Aunt Amy's "Castle" and her friend's Green Dragon Art Colony*. Fallbrook: Fallbrook Printing Company, 1993.
- Fagot, Larry. "Cooperative Tree-Loss Mitigation." *Environmental Newsletter* Vol. 1, Number 2. Caltrans. 1993.
- Farmer, Jared. "Gone Native, California's Love-Hate Relationship with Eucalyptus Trees." *Huntington Frontiers*, Spring/Summer, 2007.
- Ham, Thomas, Larry F. Fagot, and Vanessamarie F. Elwell. "State Route 67/78 Ramona, Tree Report, Preservation of a Scenic Resource (11-SD-67/78, PM 20.0-24.4/33.8-40.8, 11255-910030." Unpublished manuscript on file at Caltrans, District 11, San Diego, 1992.
- LeMenager, Charles R. *Ramona & Roundabout; A History of San Diego County's Little Known Back Country*. Ramona: Eagle Peak Publishing Company, 1989.
- Pendray, Julie. "Ramona's Colonnade from 1909 to Today." *Sentinel Magazine*, 2008.
- Pourade, Richard F. *The Silver Dons...and the Pioneers Who Overwhelmed California*. San Diego: The Union-Tribune, 1963.
- _____. *The Glory Years...The Booms and Busts in the Land of the Sundown Sea*. San Diego: The Union-Tribune, 1964.
- Santos, Robert L. "The Eucalyptus of California," Section One: The Early Years." Denair: Alley-Cass Publications, 1997a. [HYPERLINK <http://www.library.csustan.edu/bsantos/section1.htm>]
- Santos, Robert L. "The Eucalyptus of California," Section Two: Physical Properties and Uses." Denair: Alley-Cass Publications, 1997b. [HYPERLINK <http://www.library.csustan.edu/bsantos/section2.htm>]
- Santos, Robert L. "The Eucalyptus of California," Section Three: Problems, Cares, Economics and Species." Denair: Alley-Cass Publications. 1997c. [HYPERLINK <http://www.library.csustan.edu/bsantos section 3.htm>]

Ramona Main Street Colonnade
Name of Property

San Diego, CA
County and State

Smith, Joe. "The 'Signature' of our Town, the Hallway of Eucalyptus Trees." *Ramona Magazine*, 1995.

Stanford, Leland G. "San Diego's Eucalyptus Bubble." *Journal of San Diego History*, Vol. 16, No. 4, Fall, 1970.

Van Wormer, Stephen R. *A History of Jamacha Valley: Agricultural and Community Development in Southern California*. Master's thesis, San Diego State University, 1986a.

_____. "Beeves and Bees: A History of the Settlement of Pamo Valley, San Diego County." *Southern California Quarterly* 68(Spring):37-64, 1986b.

Welch, Laurie. "Historic Resource Evaluation Report for SR-67/78 Ramona Eucalyptus Trees, Ramona, San Diego County, California (11-SD-67, P.M. 20.75/24.33, 11341-079500; 11SD-78, P.M. 35.55/37.735, 11341-079500). Unpublished Manuscript on file at Caltrans District 11, Environmental Branch, 2000.

Newspapers

Baker, David. "Those Dastardly Eucalyptus Trees," Letter to the Editor. *Ramona Sentinel*, 2008.

Brandes, Connie. "Serving a Purpose," Letter to the Editor. *Ramona Sentinel*, 1990.

Brown, Peter. "Eucalyptus Tree Campaign Started, Stretch of Famed Ramona Landmarks Threatened by Highway 67 Project Plan." *The San Diego Union*, 1970.

Clark, Brian E. "Ramona Mourns Its Lost 'eucs'." *San Diego Union-Tribune*, 2001.

Conklin, Diane. "2009: Colonnade's centennial year." *Ramona Sentinel*, 2009.

Cuyamaca News. 4-28-1909, quoted in the *Ramona Sentinel*, 2-23-51:2.

Fiddes, Cindy S. Photo and Caption regarding Colonnade. *Ramona Sentinel*, 1990.

Glass, Lisa. "Ramona Planning Group Supports Preservation of Historic Tree Colonnade." *North County Times*, 2001.

Graham, David. "Trees, Conservancy to Fund Replanting Projects." *The San Diego Union-Tribune*, 1993.

Hall, Timothy Jay. "Ramona Tree Trust Adopt a Highway Sign," Photo. *Ramona Sentinel*, 2008.

Hasley, Bruce. "Tree-saving Proposal May Take Root in Ramona." *Ramona Sentinel*, 1990.

Kasper, Denise. "More than 70 eucalyptus trees cut down in Ramona." *Ramona Sentinel*, 1994.

Kelly, Barbara. "Mrs. John Bargar – 83 Years in Ramona." *Ramona Sentinel*, 1974.

Kelly, Barbara. "Ramona's First Hotel." *Ramona Sentinel*, 1974.

Kelly, Barbara. "Map of Ramona Schools," originally published in 1947 El Ano, Ramona High School Commemorative Annual. *Ramona Sentinel*, 1974.

Leins, Eric. "Response to Local Tree News Should be Applauded, Aided." *Ramona Sentinel*, 2001.

Littlefield, Larry. "13 Eucalyptus Trees Downed to Widen Road." *Ramona Sentinel*, 1990.

McNulty, Kevin. "'You're Welcome,' from Ramona Tree Trust." *Ramona Sentinel*, 2008.

Ramona Main Street Colonnade
Name of Property

San Diego, CA
County and State

North County Times. "Ramona Trees are in Danger," Letter to the Editor. 2008.

Pendergraft, George (Executive Secretary, Ramona Chamber of Commerce). "Letter to Editor." *Ramona Sentinel*, 1973.

Ramona Sentinel. "Eucalyptus Trees are Planted Along Highway by Legion." 1931.

Ramona Sentinel. "At Last-Hwy 67-78 Overlay Work Begun." 1967.

Ramona Sentinel. "Ramona to Remain Farm Area Say Planners." 1967.

Ramona Sentinel. "Highway Refurbish'g to Begin." 1967.

Ramona Sentinel. "Highway Widening Project Begun." 1973.

Ramona Sentinel. "Tree Trust Plants 25 Trees." 2003.

Robertson, Maureen. "Trees Split Planners." *Ramona Sentinel*, 1988.

San Diego Union. "Ramona's Work and Pleasures." 3-23-1904.

____ "Ramona Heads Tree Movement." 9-9-08

____ "Eucalyptus Trees Skirt 3 Miles of County Road, 9-14-09.

Selm, Allan. "Protect Heritage, Character," Letter to the Editor. *Ramona Sentinel*, 1990.

Wells, Shirley. "Pioneers." *Ramona Sentinel*, 1986.

Williams, Cindy Parker. "Let Trees Stand Tall and Proud," Letter to the Editor. *Ramona Sentinel*, 2008.

Williams, Willie Mae. "Highway Madness-The Trees, They are a-Fallin'." *Ramona Sentinel*, 1990.

Other Sources

Alvarez, Stephen (Senior Landscape Architect, Caltrans). Letter to Diane Conklin, Ramona Tree Trust. 2000.

Fagot, Larry. "Ramona Tree Survey, Updated 4-17-07." Database on file at Caltrans, District 11. 1988-2007.

"Here is Ramona in the Valley of the Santa Maria." Ramona Brochure, 1947. On file at Ramona Pioneer Historical Society.

Jenkin, Bill (Chair, Ramona Community Planning Group). "Letter to Pedro Orso-Delgado, Caltrans." 2006.

Kelly, Alice. "Letter to Ramona Community Planning Group." 2008.

Kunkel Family File, Ramona Pioneer Historical Society Research Archives. n.d.

Parker, Philip (Barnett Ranch). Personal communication, 1998.

Ramona Community Planning Group. Letter to Diane Jacob, San Diego County Supervisor. 2001.

Ramona Community Planning Group. "Ramona Community Planning Survey." 2006.

Ramona Main Street Colonnade
Name of Property

San Diego, CA
County and State

"Ramona, Land of Good Neighbors, Above the Fog...Below the Frost." Ramona Brochure, 1953. On file at Ramona Pioneer Historical Society.

Ramona Chamber of Commerce. "Ramona, The Valley of the Sun." Brochure on file at Ramona Pioneer Historical Society. Circa 1960.

Ramona Chamber of Commerce. "Ramona, San Diego County, California, Heart of the Heaven on Earth Country, Ramona's Western Approach." Brochure on file Ramona Pioneer Historical Society. n.d.

Ramona Village Design Committee. "Meeting Minutes." 2005.

Ramona Tree Trust, "Press Release." 2002.

San Diego County General Plan, Ramona Community Plan. Adopted 10-5-78, Amended 5-10-06.

San Diego County Recorder's Records. Records cited in text. 1890.

United States Census. The Tenth Census of the United States: Report on the Production of Agriculture, Vol. 3. Government. 1883.

___ Printing Office, Washington, D.C. 1890.

Aerial Photographs

Aerial photographs as cited in text. San Diego County, Cartographic Services Department, 1928, 1949, 1953, 1960/62.

Da Pron, Len. Aerial photographs of Main Street Ramona. Ramona Pioneer Historical Society, 1967.

Previous documentation on file (NPS):

___ preliminary determination of individual listing (36 CFR 67) has been requested

___ previously listed in the National Register

___ previously determined eligible by the National Register

___ designated a National Historic Landmark

___ recorded by Historic American Buildings Survey # _____

___ recorded by Historic American Engineering Record # _____

___ recorded by Historic American Landscape Survey # _____

Primary location of additional data:

___ State Historic Preservation Office

X Other State agency

___ Federal agency

X Local government

___ University

Ramona Main Street Colonnade
Name of Property

San Diego, CA
County and State

Other

Name of repository: Ramona Tree Trust, Ramona Pioneer Historical Society,
California Department of Transportation-District 11, County of San Diego Cartographic
Services, San Diego Historical Society, Internet

Historic Resources Survey Number (if assigned): _____

10. Geographical Data

Acree of Property Approximately 1.75 acres (1.8 miles) of California Department of
Transportation public right-of-way.

Use either the UTM system or latitude/longitude coordinates

Latitude/Longitude Coordinates (decimal degrees)

Datum if other than WGS84: _____

(enter coordinates to 6 decimal places)

- | | |
|------------------------|------------------------|
| 1. Latitude: 33.026230 | Longitude: -116.892063 |
| 2. Latitude: 33.035135 | Longitude: -116.880568 |
| 3. Latitude: 33.042885 | Longitude: -116.867035 |
| 4. Latitude: | Longitude: |

Verbal Boundary Description (Describe the boundaries of the property.)

The Colonnade extends approximately 1.8 miles on the northwest and southeast sides of Ramona's Main Street from Wynola Street on the west to 9th Street on the east. UTM Coordinates are "11S, 510078 meters east/3654190 meters north" at Main Street and Wynola Street and "11S, 512405 meters east/3656054 meters north" at Main Street and 9th Street. The Colonnade trees exist within an 8-foot California Department of Transportation right-of-way. (Boundaries and detailed mapping are shown on Continuation Sheets, Additional Documentation, pages 1-2 and 4-11).

Boundary Justification (Explain why the boundaries were selected.)

The boundaries encompass the 226 historic eucalyptus trees that are shown on the historic aerial photographs (1928, 1949, 1953, 1960/2) and that were documented to remain in existence during the February 2009 detailed field update of the Caltrans Tree Inventory. An additional 80 eucalyptus trees planted over the past century by the Ramona community are included within this boundary and contribute to the significance and integrity of the Colonnade.

Ramona Main Street Colonnade
Name of Property

San Diego, CA
County and State

11. Form Prepared By

name/title: Sue A. Wade, Historian; Carolyn Dorroh, AutoCad Specialist
organization: Ramona Tree Trust & Heritage Resources
street & number: P.O. Box 683
city or town: Ramona state: CA zip code: 92065
e-mail: DJ0conklin@earthlink.net
telephone: 760-787-0794
date: May 5, 2014

Additional Documentation

Submit the following items with the completed form:

- **Maps:** A **USGS map** or equivalent (7.5 or 15 minute series) indicating the property's location. See Attached Continuation Sheet, Pages 1 and 2
- **Sketch map** for historic districts and properties having large acreage or numerous resources. Key all photographs to this map. See Attached Continuation Sheet, Pages 3 through 11
- **Additional items:** (Check with the SHPO, TPO, or FPO for any additional items.)
- **Historical Photographs:** See Attached Continuation Sheet, Pages 12 through 14

Photographs

Submit clear and descriptive photographs. The size of each image must be 1600x1200 pixels (minimum), 3000x2000 preferred, at 300 ppi (pixels per inch) or larger. Key all photographs to the sketch map. Each photograph must be numbered and that number must correspond to the photograph number on the photo log. For simplicity, the name of the photographer, photo date, etc. may be listed once on the photograph log and doesn't need to be labeled on every photograph. See Attached

Ramona Main Street Colonnade
Name of Property

San Diego, CA
County and State

Photo Log – 2009-02-14 Photographs (Numbers 10 and 11 on Continuation Sheet, on Photo Log below, and keyed to U.S.G.S. 7.5-minute map)

Name of Property: Ramona Main Street Eucalyptus Colonnade

City or Vicinity: Ramona, CA

County: San Diego State: CA

Photographer: Sue A. Wade

Date Photographed: 2014-02-14

Description of Photograph(s) and number, include description of view indicating direction of camera:

1 of 2: Eucalyptus trees along Main Street at west end of Colonnade, at Julian Street, view to northeast

2 of 2: Eucalyptus trees along Main Street at west end of Colonnade, at Rotanzi Street, view to northeast

Paperwork Reduction Act Statement: This information is being collected for applications to the National Register of Historic Places to nominate properties for listing or determine eligibility for listing, to list properties, and to amend existing listings. Response to this request is required to obtain a benefit in accordance with the National Historic Preservation Act, as amended (16 U.S.C.460 et seq.).

Estimated Burden Statement: Public reporting burden for this form is estimated to average 100 hours per response including time for reviewing instructions, gathering and maintaining data, and completing and reviewing the form. Direct comments regarding this burden estimate or any aspect of this form to the Office of Planning and Performance Management, U.S. Dept. of the Interior, 1849 C. Street, NW, Washington, DC.

United States Department of the Interior
National Park Service

Ramona Main Street Colonnade
Name of Property
San Diego, CA
County and State
N/A
Name of multiple listing (if applicable)

National Register of Historic Places Continuation Sheet

Section number: Additional Documentation (U.S.G.S. Maps, Google Earth Imagery, AutoCad Maps, Historic Photos, Photo Log for Current Photos on CD) Page 1

SOUTHERN CALIFORNIA U.S.G.S. MAP 1 inch = 8.5 miles **áN**

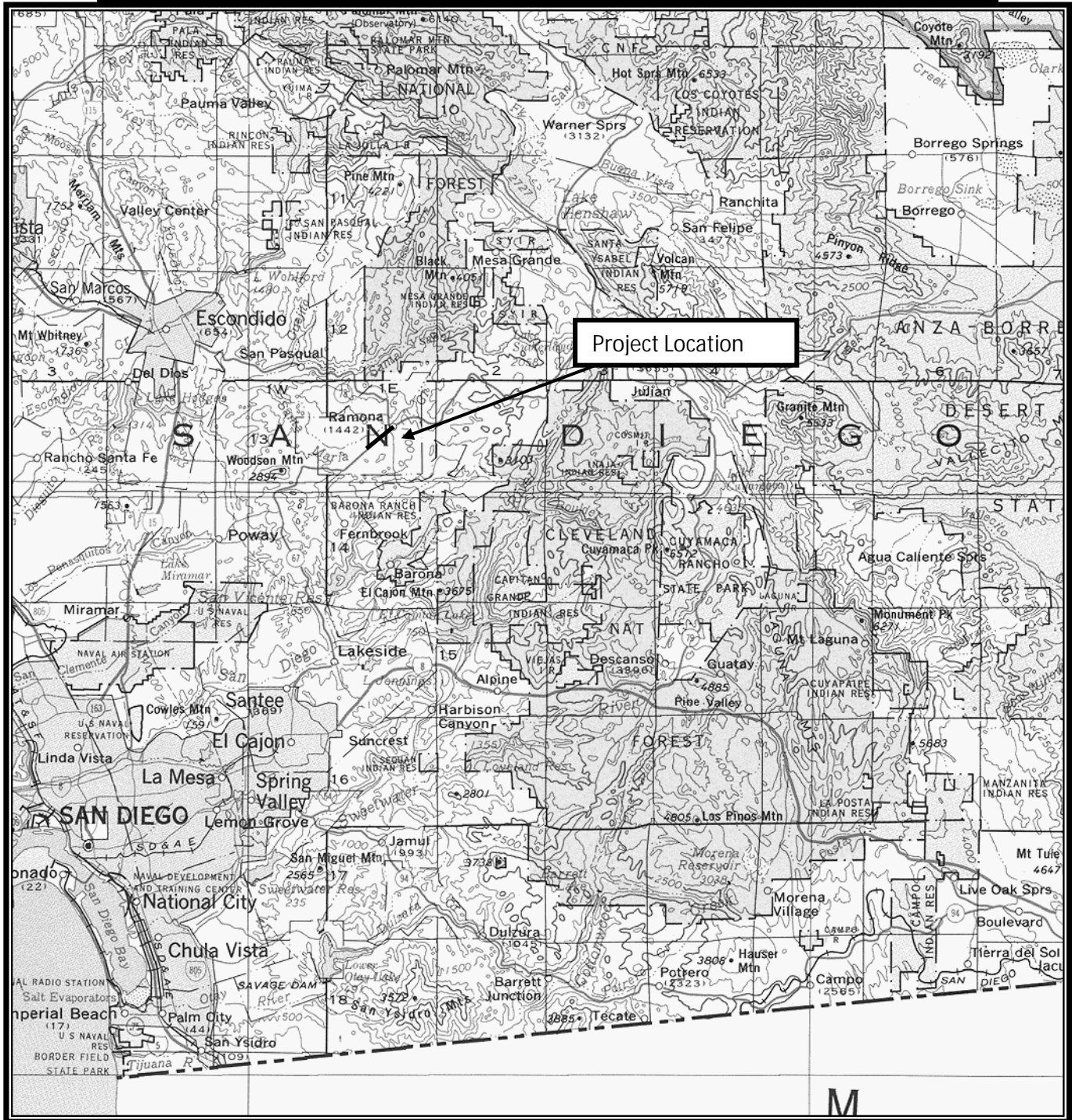

United States Department of the Interior
National Park Service

National Register of Historic Places Continuation Sheet

Ramona Main Street Colonnade

Name of Property

San Diego, CA

County and State

N/A

Name of multiple listing (if applicable)

Section number: Additional Documentation (U.S.G.S. Maps, Google Earth Imagery, AutoCad Maps, Historic Photos, Photo Log for Current Photos on CD) Page 2

RAMONA AND SAN PASQUAL U.S.G.S. MAPS 1 inch = 2000 feet \uparrow N

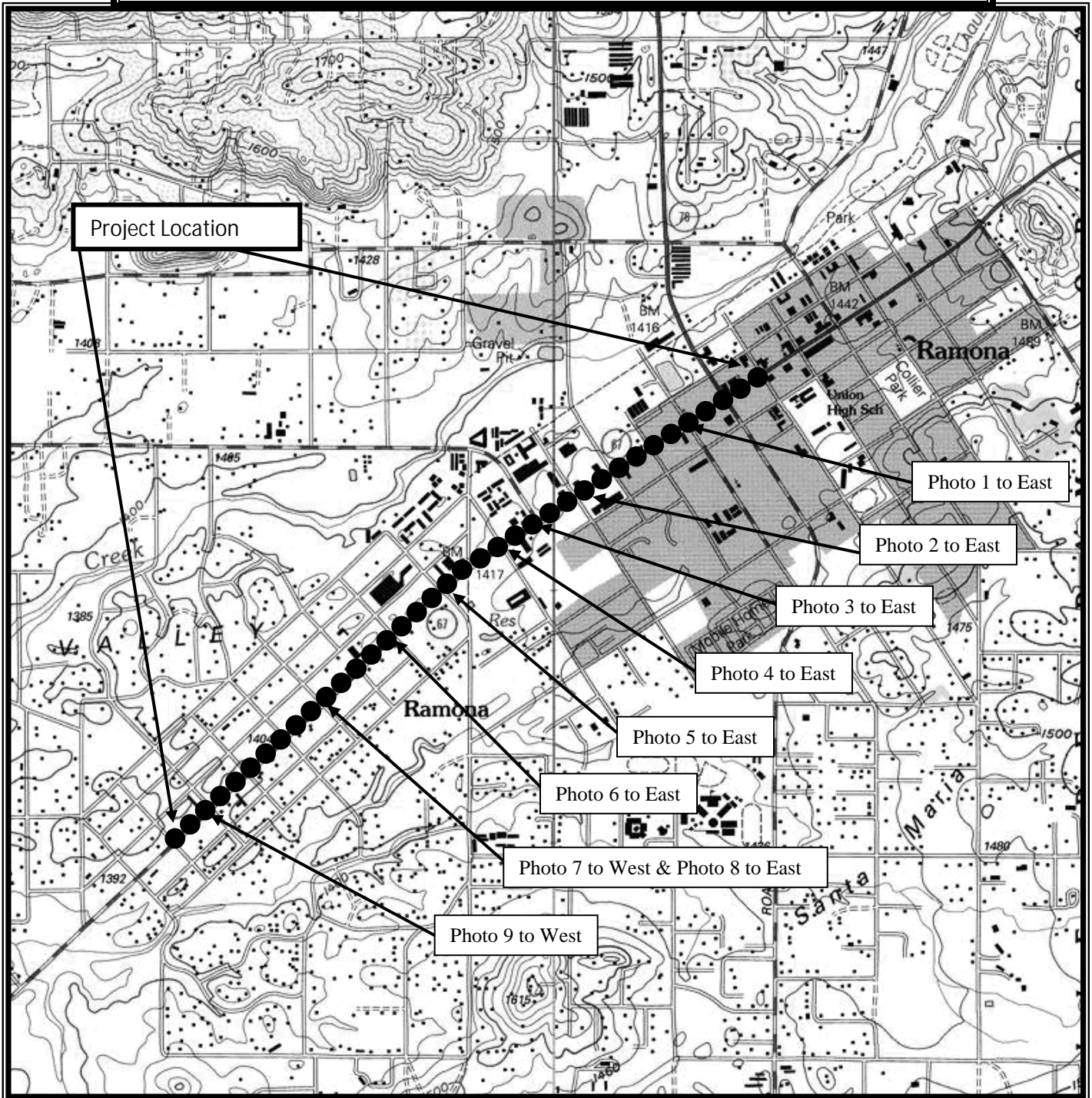

United States Department of the Interior
National Park Service

National Register of Historic Places Continuation Sheet

Ramona Main Street Colonnade
Name of Property
San Diego, CA
County and State
N/A
Name of multiple listing (if applicable)

Section number: Additional Documentation (U.S.G.S. Maps, Google Earth Imagery, AutoCad Maps, Historic Photos, Photo Log for Current Photos on CD) Page 3

Google Earth Aerial (Imagery Date: 11/8/2016)

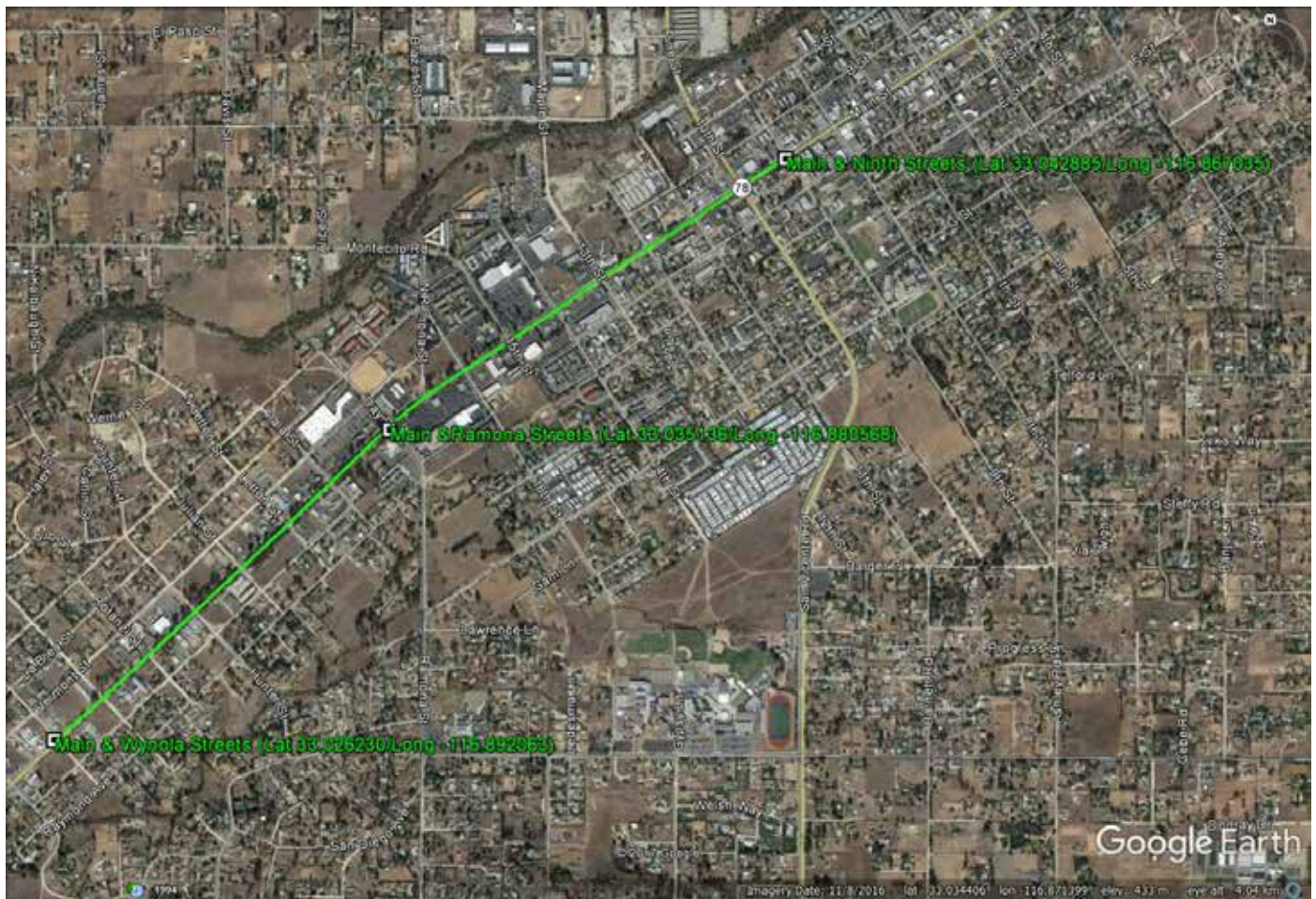

United States Department of the Interior
National Park Service

Ramona Main Street Colonnade

Name of Property

San Diego, CA

County and State

N/A

Name of multiple listing (if applicable)

National Register of Historic Places Continuation Sheet

Section number: Additional Documentation (U.S.G.S. Maps, Google Earth Imagery, AutoCad Maps, Historic Photos, Photo Log for Current Photos on CD) Page 4

Colonnade Tree Inventory in 1928 (from 1928 aerial photographs)

Wynola Street to Letton Street, 184 trees

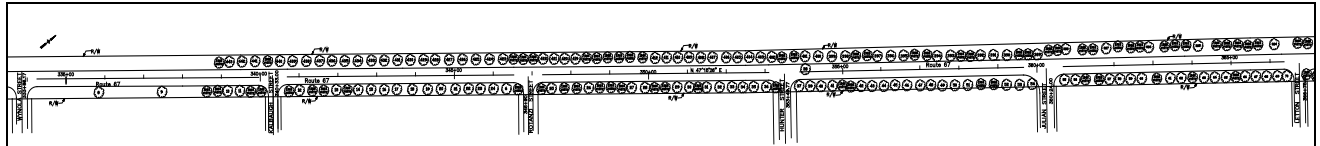

Letton Street to Montecito Road, 262 trees

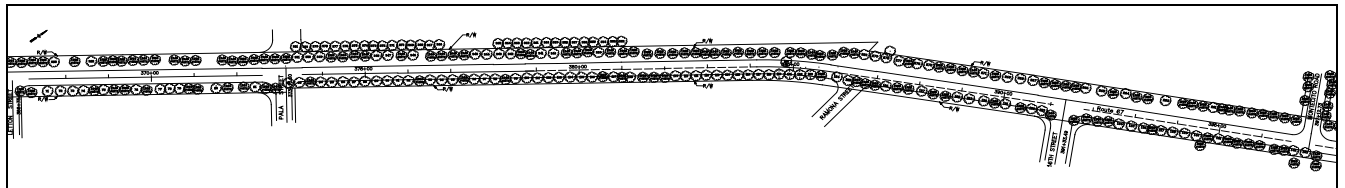

Montecito Road to 9th Street, 180 trees

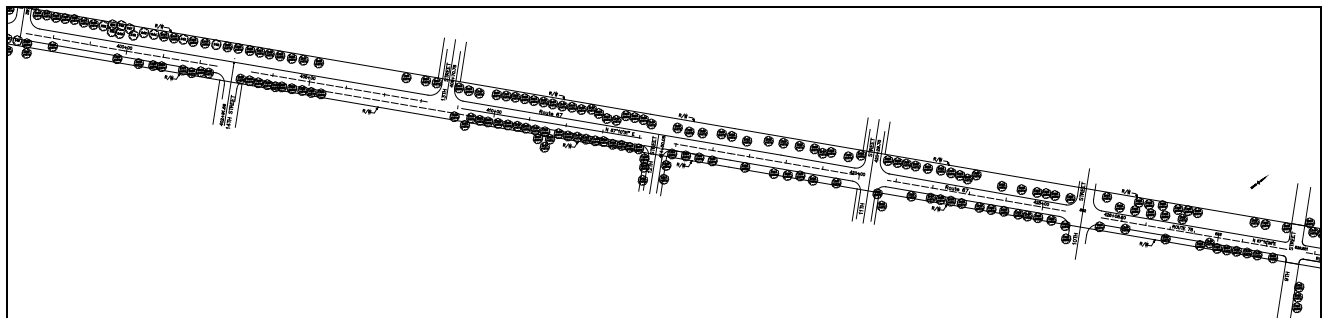

United States Department of the Interior
National Park Service

**National Register of Historic Places
Continuation Sheet**

Ramona Main Street Colonnade
Name of Property
San Diego, CA
County and State
N/A
Name of multiple listing (if applicable)

Section number: Additional Documentation (U.S.G.S. Maps, Google Earth Imagery, AutoCad Maps, Historic Photos, Photo Log for Current Photos on CD) Page 5

Colonnade Tree Inventory in 2009 (from 2009 Field Survey), page 1 of 8

Wynola Street to Kalbaugh Street

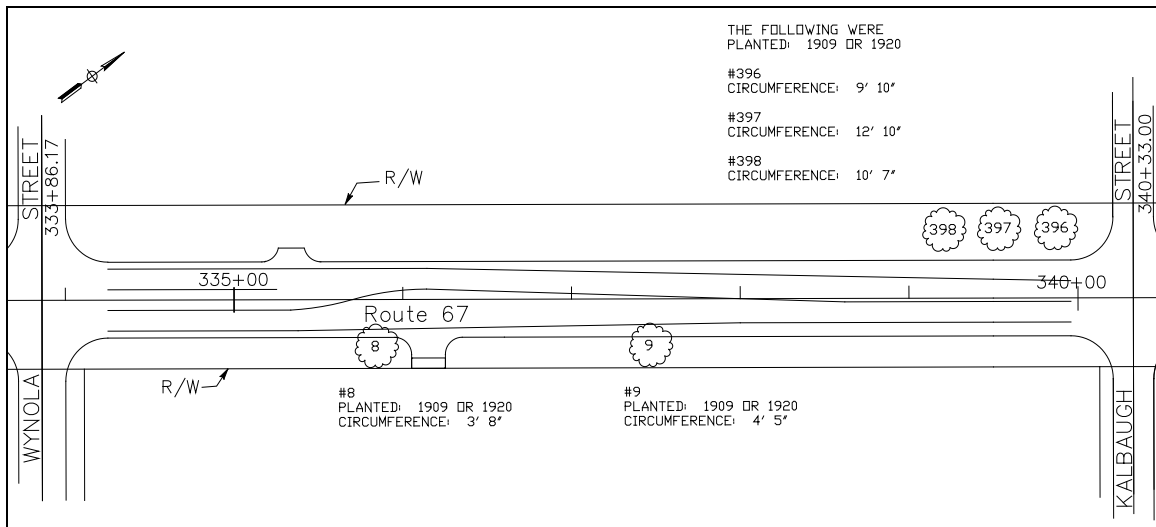

Kalbaugh Street to Rotanzi Street

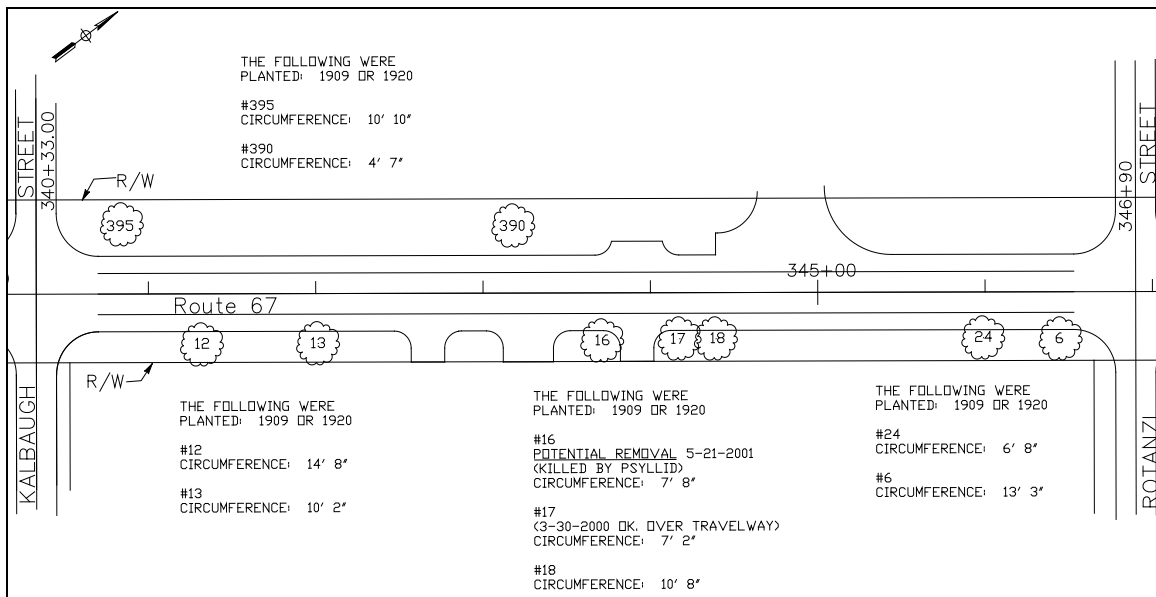

United States Department of the Interior
National Park Service

**National Register of Historic Places
Continuation Sheet**

Ramona Main Street Colonnade
Name of Property
San Diego, CA
County and State
N/A
Name of multiple listing (if applicable)

Section number: Additional Documentation (U.S.G.S. Maps, Google Earth Imagery, AutoCad Maps, Historic Photos, Photo Log for Current Photos on CD) Page 6

Colonnade Tree Inventory in 2009 (from 2009 Field Survey), page 2 of 8

Rotanzi Street to Hunter Street

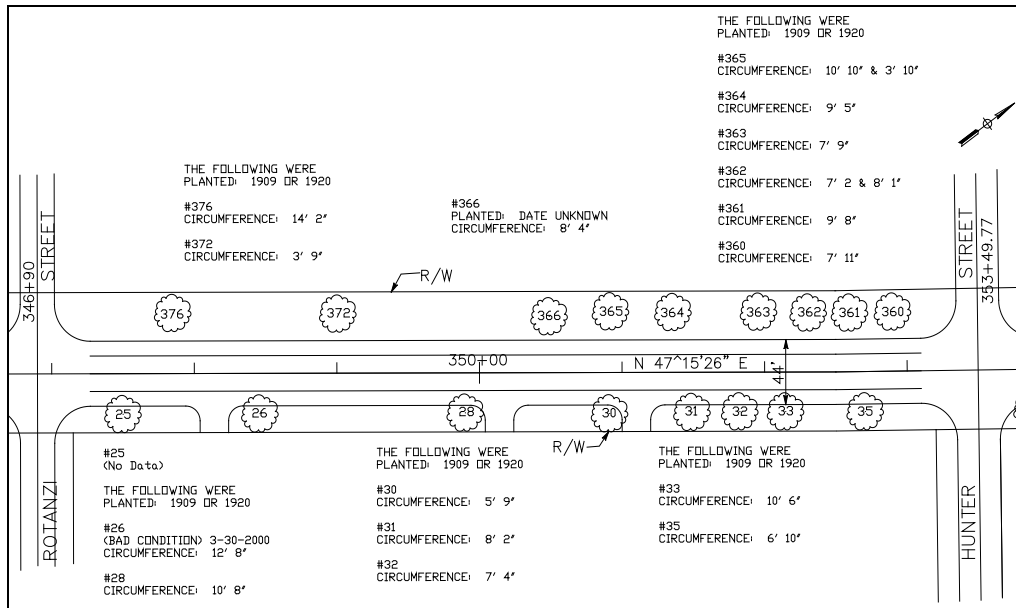

Hunter Street to Julian Street

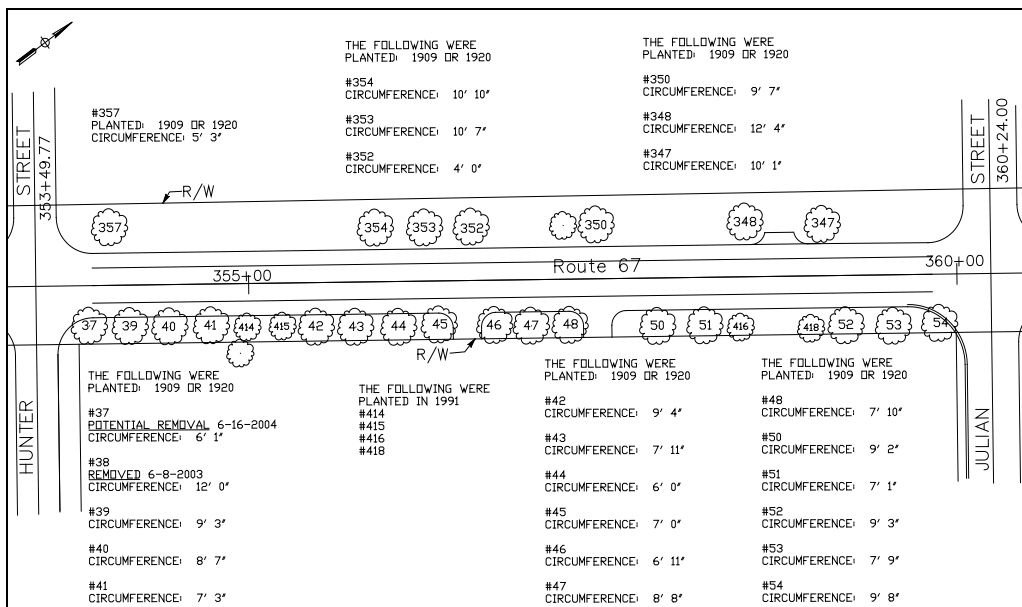

United States Department of the Interior
National Park Service

Ramona Main Street Colonnade
Name of Property San Diego, CA
County and State N/A
Name of multiple listing (if applicable)

**National Register of Historic Places
Continuation Sheet**

Section number: Additional Documentation (U.S.G.S. Maps, Google Earth Imagery, AutoCad Maps, Historic Photos, Photo Log for Current Photos on CD) Page 7

Colonnade Tree Inventory in 2009 (from 2009 Field Survey), page 3 of 8

Julian Street to Letton Street

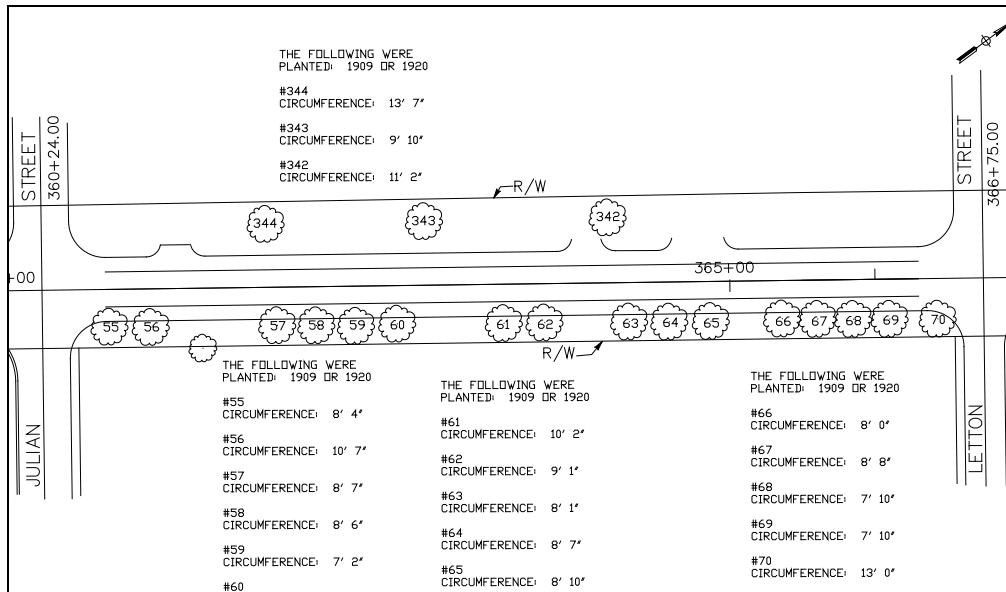

Letton Street to Pala Street

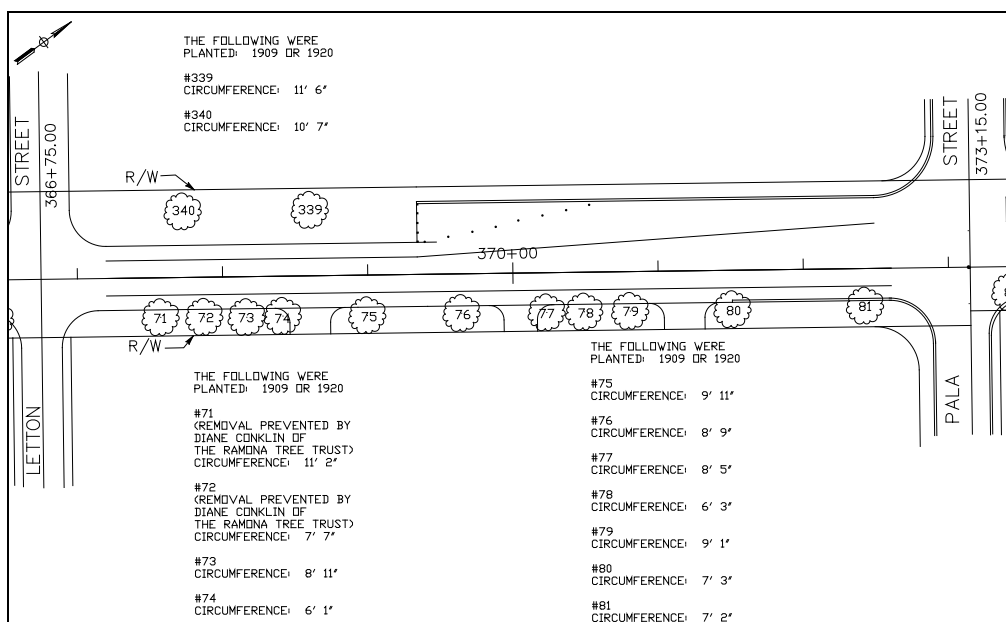

United States Department of the Interior
National Park Service

Ramona Main Street Colonnade
Name of Property
San Diego, CA
County and State
N/A
Name of multiple listing (if applicable)

**National Register of Historic Places
Continuation Sheet**

Section number: Additional Documentation (U.S.G.S. Maps, Google Earth Imagery, AutoCad Maps, Historic Photos, Photo Log for Current Photos on CD) Page 8

Colonnade Tree Inventory in 2009 (from 2009 Field Survey), page 4 of 8

Pala Street to Day Street

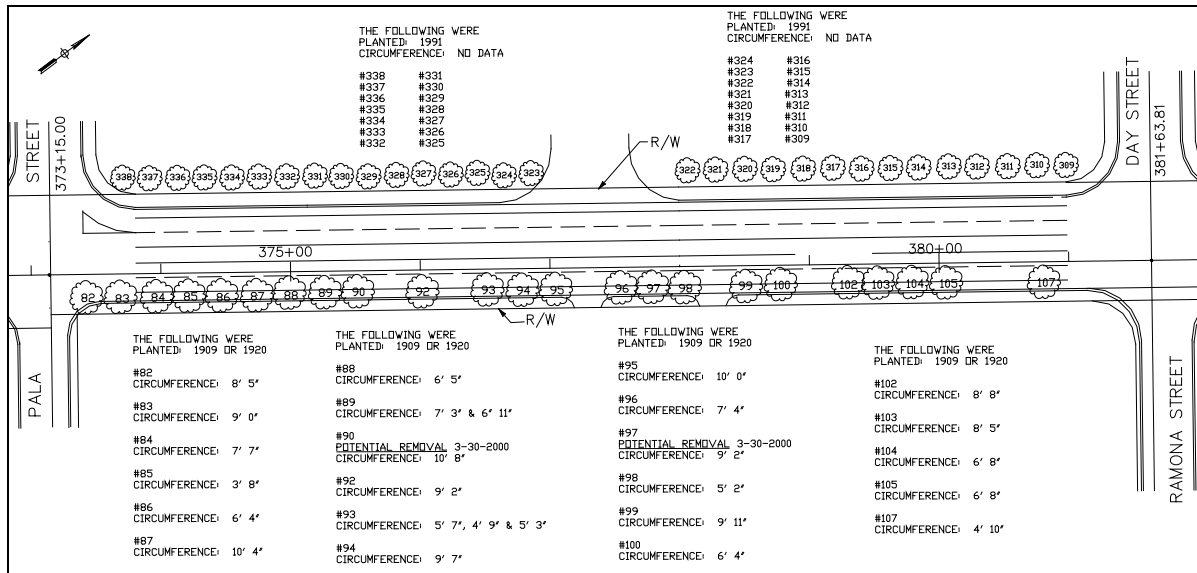

Day Street to Ramona Street

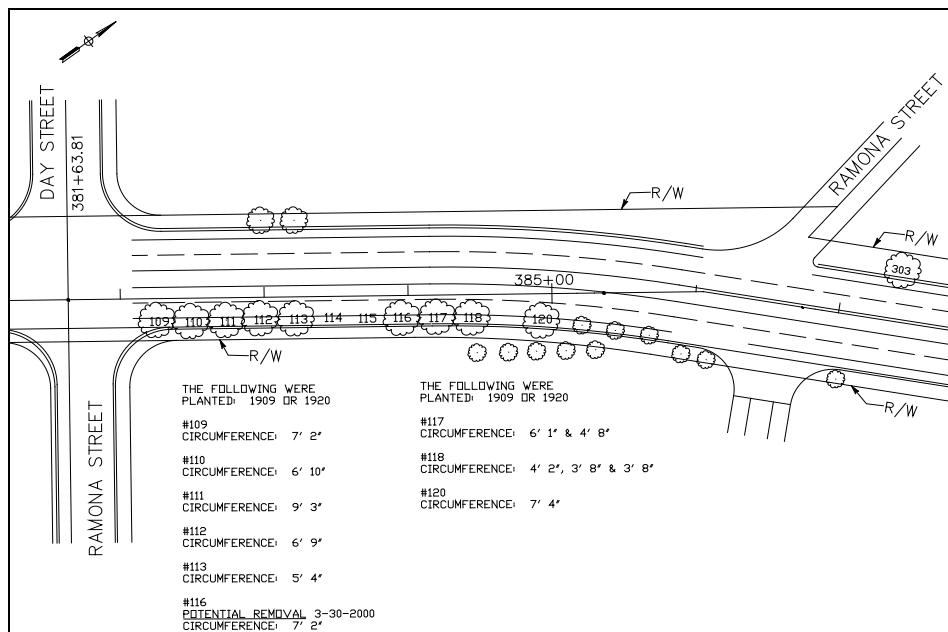

United States Department of the Interior
National Park Service

**National Register of Historic Places
Continuation Sheet**

Ramona Main Street Colonnade
Name of Property
San Diego, CA
County and State
N/A
Name of multiple listing (if applicable)

Section number: Additional Documentation (U.S.G.S. Maps, Google Earth Imagery, AutoCad Maps, Historic Photos, Photo Log for Current Photos on CD) Page 9

Colonnade Tree Inventory in 2009 (from 2009 Field Survey), page 5 of 8

Ramona Street to 16th Street

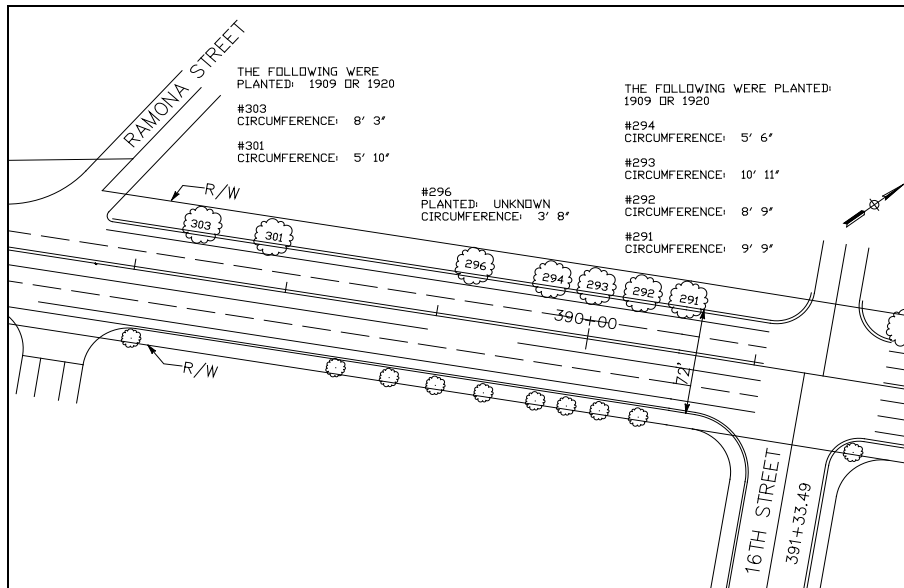

16th Street to Montecito Road

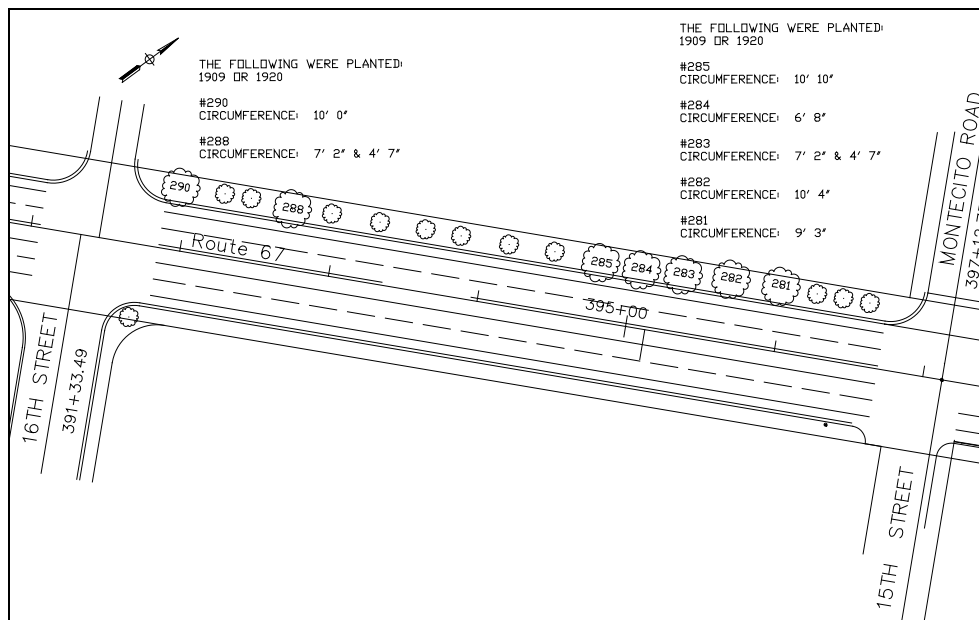

United States Department of the Interior
National Park Service

Ramona Main Street Colonnade
Name of Property
San Diego, CA
County and State
N/A
Name of multiple listing (if applicable)

National Register of Historic Places Continuation Sheet

Section number: Additional Documentation (U.S.G.S. Maps, Google Earth Imagery, AutoCad Maps, Historic Photos, Photo Log for Current Photos on CD) Page 10

Colonnade Tree Inventory in 2009 (from 2009 Field Survey), page 6 of 8

Montecito Road to 14th Street

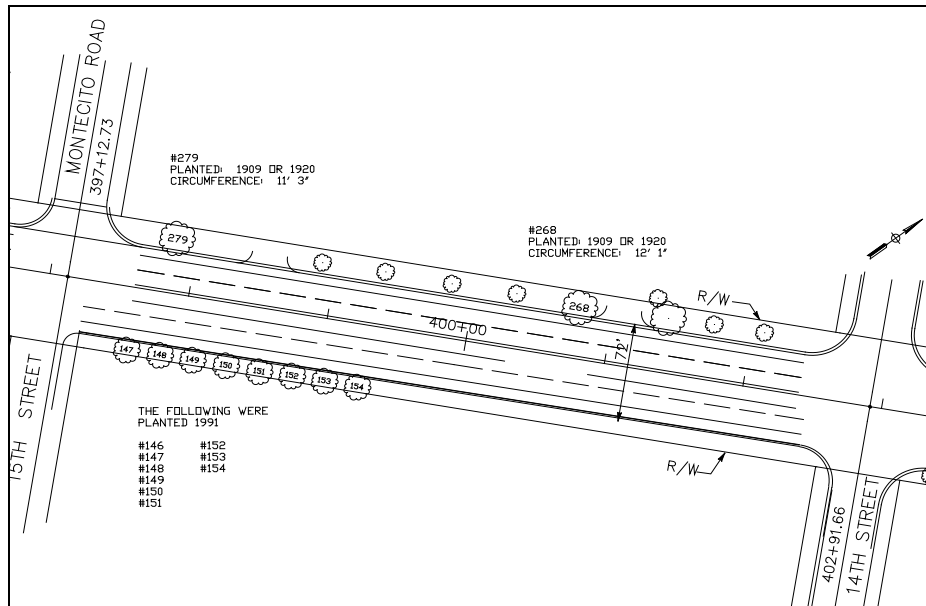

14th Street to 13th Street

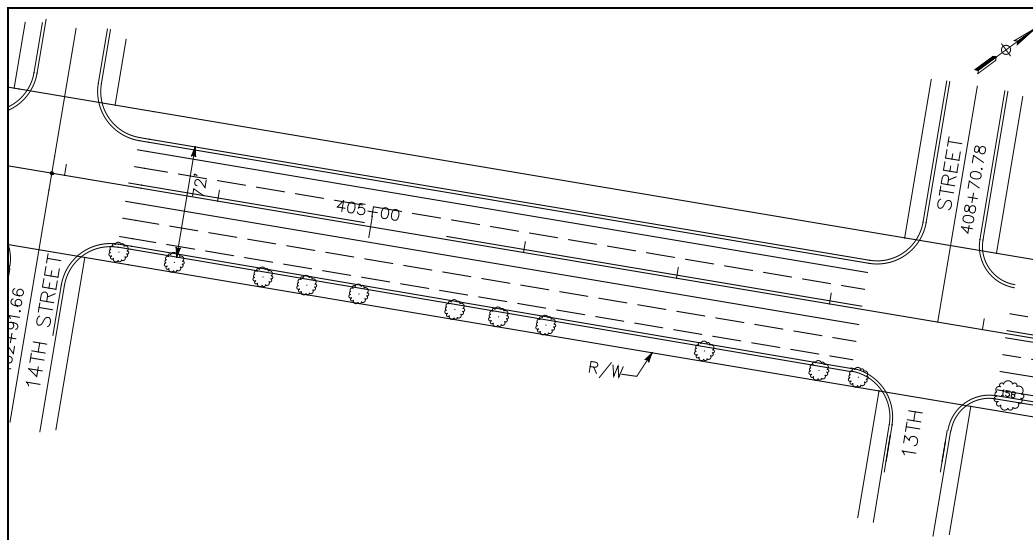

United States Department of the Interior
National Park Service

**National Register of Historic Places
Continuation Sheet**

Ramona Main Street Colonnade
Name of Property San Diego, CA
County and State N/A
Name of multiple listing (if applicable)

Section number: Additional Documentation (U.S.G.S. Maps, Google Earth Imagery, AutoCad Maps, Historic Photos, Photo Log for Current Photos on CD) Page 11

Colonnade Tree Inventory in 2009 (from 2009 Field Survey), page 7 of 8

13th Street to 12th Street

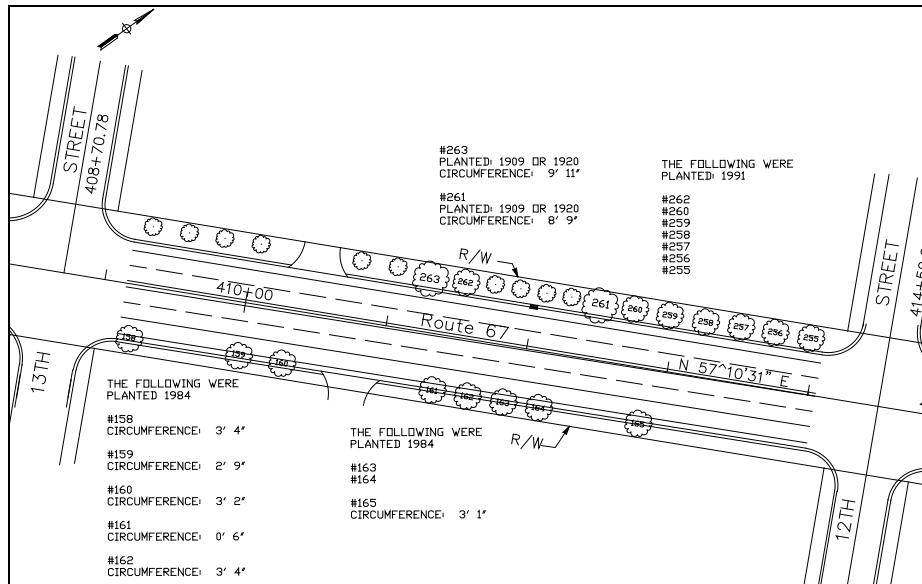

12th Street to 11th Street

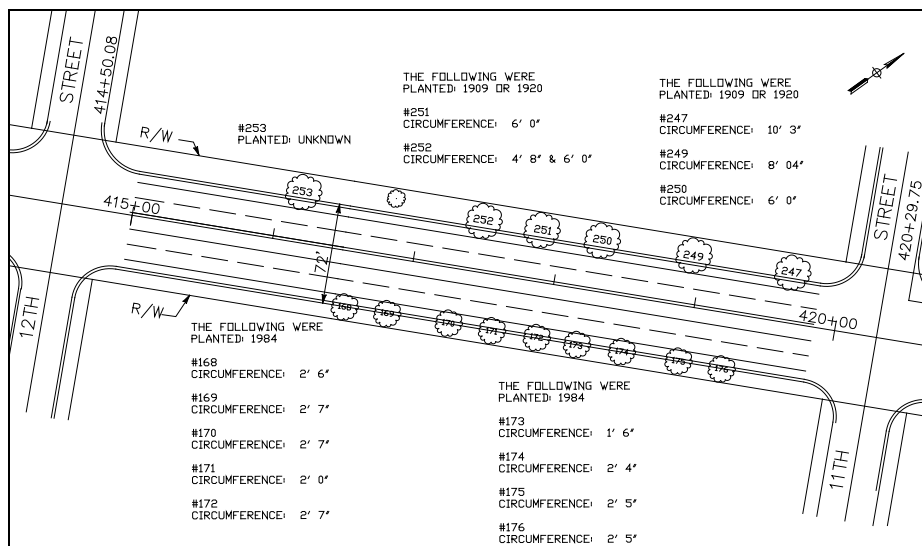

United States Department of the Interior
National Park Service

**National Register of Historic Places
Continuation Sheet**

Ramona Main Street Colonnade
Name of Property
San Diego, CA
County and State
N/A
Name of multiple listing (if applicable)

Section number: Additional Documentation (U.S.G.S. Maps, Google Earth Imagery, AutoCad Maps, Historic Photos, Photo Log for Current Photos on CD) Page 12

Colonnade Tree Inventory in 2009 (from 2009 Field Survey), page 8 of 8

11th Street to 10th Street

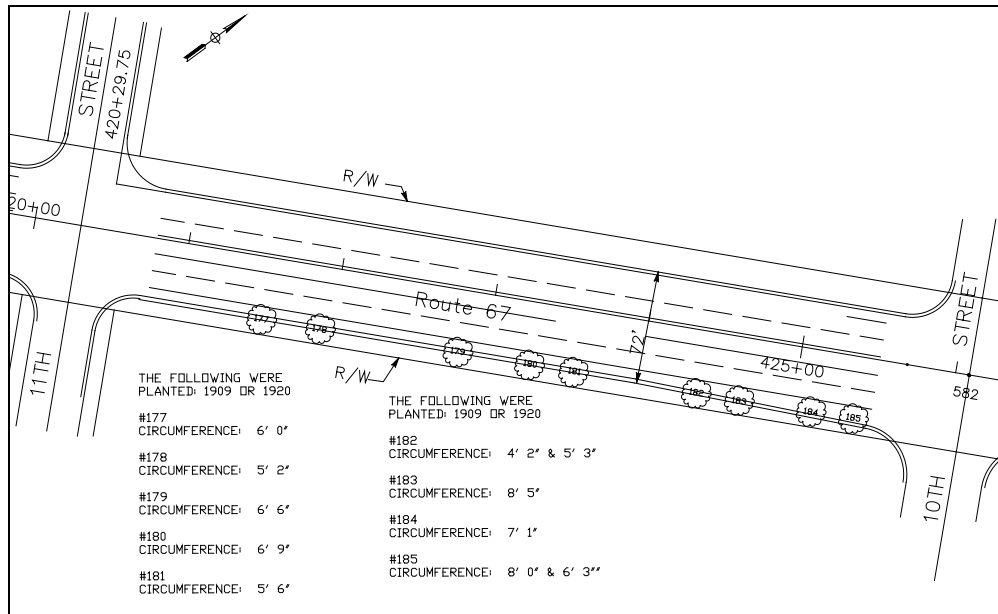

10th Street to 9th Street

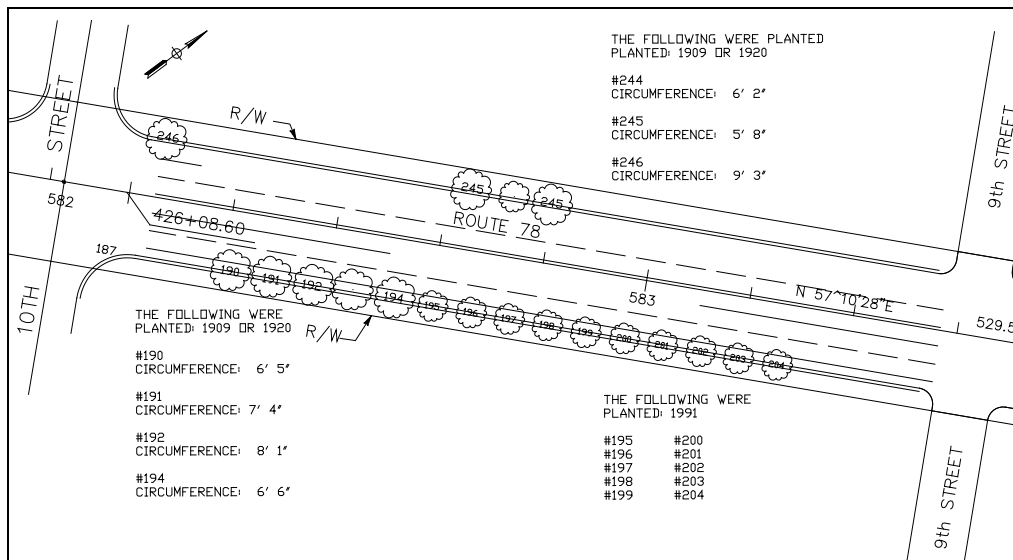

United States Department of the Interior
National Park Service

National Register of Historic Places Continuation Sheet

Ramona Main Street Colonnade
Name of Property
San Diego, CA
County and State
N/A
Name of multiple listing (if applicable)

Section number: Additional Documentation (U.S.G.S. Maps, Google Earth Imagery, AutoCad Maps, Historic Photos, Photo Log for Current Photos on CD) Page 13

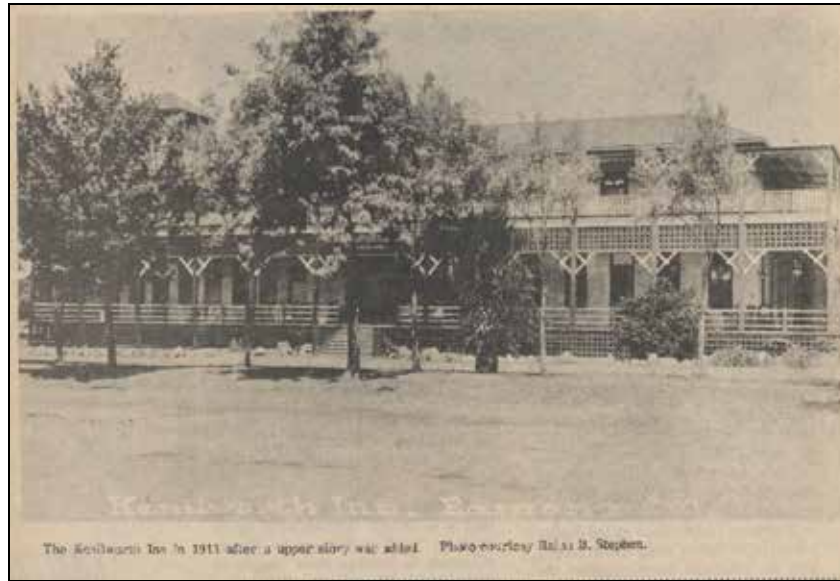

Ramona Main Street Colonnade (1915), Ramona CA
Photograph 1

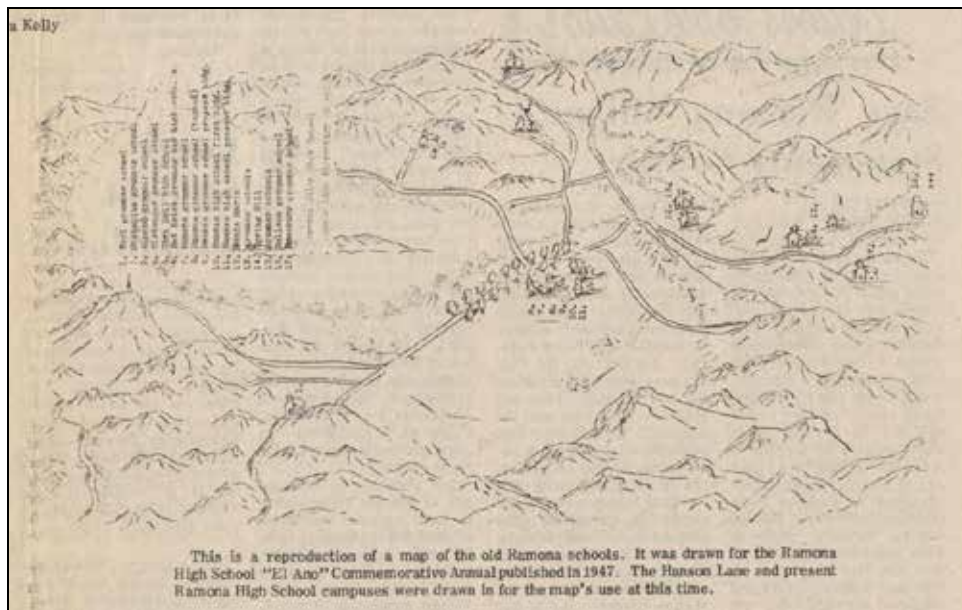

Ramona Main Street Colonnade (1947), Ramona CA
Photograph 2

United States Department of the Interior
National Park Service

National Register of Historic Places Continuation Sheet

Ramona Main Street Colonnade
Name of Property San Diego, CA
County and State N/A
Name of multiple listing (if applicable)

Section number: Additional Documentation (U.S.G.S. Maps, Google Earth Imagery, AutoCad Maps, Historic Photos, Photo Log for Current Photos on CD) Page 14



Ramona Main Street Colonnade (1947), Ramona CA
Photograph 3

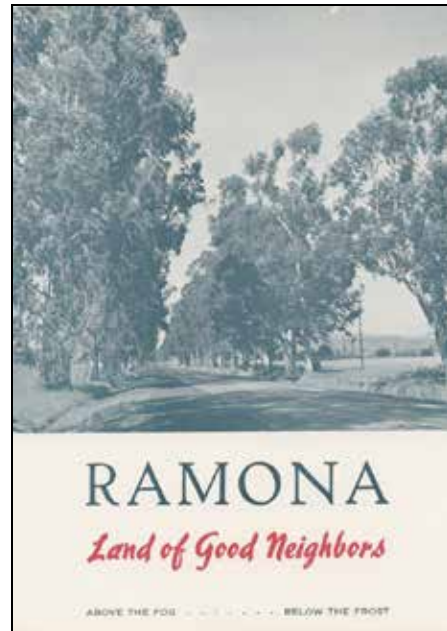

Ramona Main Street Colonnade (1953), Ramona CA
Photograph 4



Ramona Main Street Colonnade (1958), Ramona CA
Photograph 5

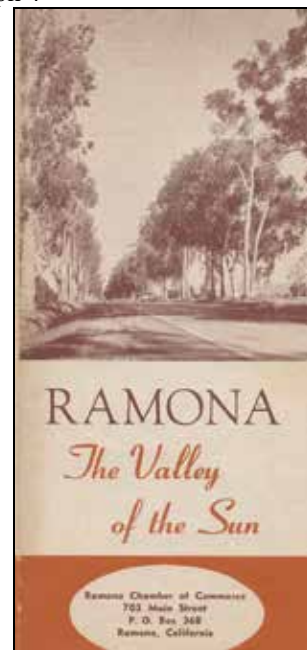

Ramona Main Street Colonnade (1960s), Ramona CA
Photograph 6

United States Department of the Interior
National Park Service

**National Register of Historic Places
Continuation Sheet**

Ramona Main Street Colonnade
Name of Property San Diego, CA
County and State N/A
Name of multiple listing (if applicable)

Section number: Additional Documentation (U.S.G.S. Maps, Google Earth Imagery, AutoCad Maps, Historic Photos, Photo Log for Current Photos on CD) Page 15



Ramona Main Street Colonnade (1986), Ramona CA
Photograph 7

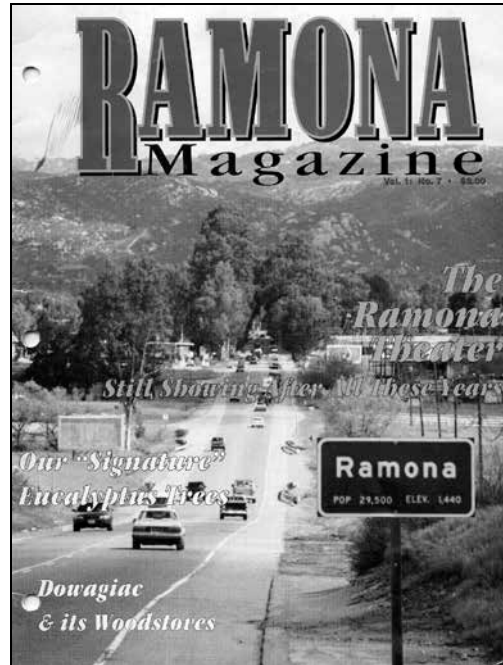

Ramona Main Street Colonnade (1995), Ramona CA
Photograph 8

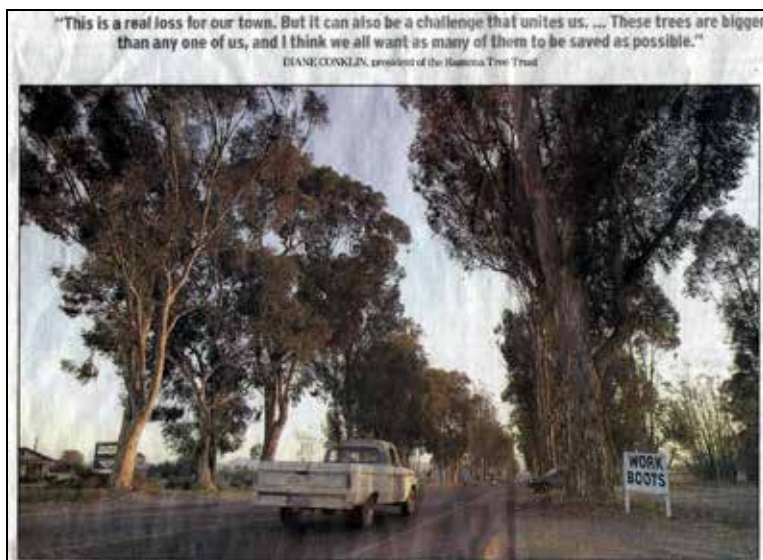

Ramona Main Street Colonnade (2001), Ramona CA
Photograph 9

United States Department of the Interior
National Park Service

**National Register of Historic Places
Continuation Sheet**

Ramona Main Street Colonnade

Name of Property
San Diego, CA

County and State
N/A

Name of multiple listing (if applicable)

Section number: Additional Documentation (U.S.G.S. Maps, Google Earth Imagery, AutoCad Maps, Historic Photos, Photo Log for Current Photos on CD) Page 16



Ramona Main Street Colonnade (February 2009), Ramona CA
Photograph 10



Ramona Main Street Colonnade (February 2009), Ramona CA
Photograph 11

United States Department of the Interior
National Park Service

National Register of Historic Places Continuation Sheet

Ramona Main Street Colonnade
Name of Property
San Diego, CA
County and State
N/A
Name of multiple listing (if applicable)

Section number: Additional Documentation (U.S.G.S. Maps, Google Earth Imagery, AutoCad Maps, Historic Photos, Photo Log for Current Photos on CD) Page 17

Historic Photographs, 1915 through 2009 (Continuation Sheet pages 12-15):

#1

Photographer: unknown
Date of Photo: 1915
Location of original: Ramona Pioneer Historical Society
Description: Eucalyptus trees along Kenilworth Inn frontage on Ramona Main Street, view to northwest

#2

Photographer: unknown
Date of Photo: 1947
Location of original: Ramona Pioneer Historical Society
Description: Eucalyptus trees depicted along Main Street entry to Ramona

#3

Photographer: unknown
Date of Photo: 1947
Location of original: Unknown
Description: Eucalyptus trees along Main Street at west end of Colonnade (approximately Rotanzi Street), view to northeast

#4

Photographer: unknown
Date of Photo: 1953
Location of original: Ramona Pioneer Historical Society
Description: Eucalyptus trees along Main Street at west end of Colonnade, view to northeast

#5

Photographer: unknown
Date of Photo: 1958
Location of original: Ramona Pioneer Historical Society
Description: Eucalyptus trees along Main Street at west end of Colonnade, view to northeast

#6

Photographer: unknown
Date of Photo: 1960s
Location of original: Ramona Pioneer Historical Society
Description: Eucalyptus trees along Main Street at west end of Colonnade, view to northeast

#7

United States Department of the Interior
National Park Service

National Register of Historic Places Continuation Sheet

Ramona Main Street Colonnade
Name of Property
San Diego, CA
County and State
N/A
Name of multiple listing (if applicable)

Section number: Additional Documentation (U.S.G.S. Maps, Google Earth Imagery, AutoCad Maps, Historic Photos, Photo Log for Current Photos on CD) Page 18

Photographer: Shirley Wells
Date of Photo: 1986
Location of original: Ramona Pioneer Historical Society
Description: Eucalyptus trees along Main Street at west end of Colonnade (at Rotanzi Street), view to northeast

#8

Photographer: Unknown
Date of Photo: 1995
Location of original: Ramona Pioneer Historical Society
Description: Eucalyptus trees along Main Street at west end of Colonnade, view to northeast

#9

Photographer: Unknown
Date of Photo: 2001
Location of original: Ramona Pioneer Historical Society
Description: Eucalyptus trees along Main Street at west end of Colonnade, view to northeast

#10

Photographer: Sue A. Wade
Date of Photo: 2-14-2009
Location of original Negative: Digital
Description: Eucalyptus trees along Main Street at west end of Colonnade, at Julian Street, view to northeast

#11

Photographer: Sue A. Wade
Date of Photo: 2-14-2009
Location of original Negative: Digital
Description: Eucalyptus trees along Main Street at west end of Colonnade, at Rotanzi Street, view to northeast

United States Department of the Interior
National Park Service

National Register of Historic Places Continuation Sheet

Ramona Main Street Colonnade
Name of Property
San Diego, CA
County and State
N/A
Name of multiple listing (if applicable)

Section number: Additional Documentation (U.S.G.S. Maps, Google Earth Imagery, AutoCad Maps, Historic Photos, Photo Log for Current Photos on CD) Page 19

Current Photographs, 2-4-2016 (Included on Attached CD):

#1

Photographer: Sue Wade
Date of Photo: 2-4-2016
Location of original: Included on Attached CD
Description: Colonnade, Main Street & 12th Street, view to east

#2

Photographer: Sue Wade
Date of Photo: 2-4-2016
Location of original: Included on Attached CD
Description: Colonnade, Main Street between 13th & 14th Streets, view to east

#3

Photographer: Sue Wade
Date of Photo: 2-4-2016
Location of original: Included on Attached CD
Description: Colonnade, Main Street & Montecito Road, view to east

#4

Photographer: Sue Wade
Date of Photo: 2-4-2016
Location of original: Included on Attached CD
Description: Colonnade, Main Street & 16th Street, view to east

#5

Photographer: Sue Wade
Date of Photo: 2-4-2016
Location of original: Included on Attached CD
Description: Colonnade, Main Street & Ramona Street, view to east

#6

Photographer: Sue Wade
Date of Photo: 2-4-2016
Location of original: Included on Attached CD
Description: Colonnade, Main Street & Pala Street, view to east

#7

Photographer: Sue Wade
Date of Photo: 2-4-2016
Location of original: Included on Attached CD
Description: Colonnade, Main Street & Julian Street west

United States Department of the Interior
National Park Service

**National Register of Historic Places
Continuation Sheet**

Ramona Main Street Colonnade

Name of Property
San Diego, CA

County and State
N/A

Name of multiple listing (if applicable)

Section number: Additional Documentation (U.S.G.S. Maps, Google Earth Imagery, AutoCad Maps, Historic Photos, Photo Log for Current Photos on CD) Page 20

#8

Photographer: Sue Wade
Date of Photo: 2-4-2016
Location of original: Included on Attached CD
Description: Colonnade, Main Street & Julian Street, view to east

#9

Photographer: Sue Wade
Date of Photo: 2-4-2016
Location of original: Included on Attached CD
Description: Colonnade, Main Street & Kalbaugh Street, view to west